

OWNER'S MANUAL

English

Rigid Inflatable Boat

MODEL: **Eagle10**

Design category (2013/53/EU): B
ISO 6185-4: Type X

CONTENTS:

4	CE CERTIFICATIONS AND MAIN FEATURES
5	DANGER LEVELS
5	INTRODUCTION
6	IDENTIFICATION PLATES
7	BEAUFORT Wind Scale and Corresponding State of the Sea, After Few Hours of Wind, Away From the Coast.
7	Boat Design Categories
8	SAFETY REGULATIONS
9	REMEMBER FIRE DANGER ALWAYS
10	TECHNICAL SPECIFICATIONS
11	COMPLETE SETS
12	BOAT DESIGN
14	RIGID HULL
15	REINFORCED BUOYANCY TUBE
16	STEERING CONSOLE
18	THE CABIN
20	WASTER-WATER SYSTEM
23	SHOWER SYSTEM
24	FUEL SYSTEM
25	DRAIN SYSTEM
26	ANCHOR SYSTEM
29	STORAGE BATTERIES INSTALLATION
30	HOW TO INSTAL A TABLE
31	HOW TO INSTALL SUNDECK
33	INFLATION/DEFLATION BOAT TUBE
34	BOAT TRANSPORTATION BY TRAILER
35	MAINTENANCE
36	REBOARDING MEANS
37	OPERATING REGULATIONS



For your safety and for the validity of the guarantee expert and authorised personnel must install the motor and inspect and check the systems. All onboard systems must be completed and inspected.

CHECK, THAT THE CHECKS HAVE BEEN MADE AND THAT THE PLANTS HAVE BEEN COMPLETED BEFORE DELIVERY.

BRIG Ltd declines any responsibility for systems and accessories that have not been installed and checked by expert and authorised personnel.



The manual and all its enclosures should be stored carefully, and the manual should always be kept aboard. If the craft is resold, the manual and all its enclosures must be handed over to the new owner.

CE Certification and Main Features

The CE marking indicates that the inflatable boat meets the requirements of the
Recreational Craft Directive 2013/53/EU

Certifying Body:

HPI Verification Services Ltd.

The Manor House
Howbery Park, Wallingford,
OX10 8BA, United Kingdom
EU Notified Body No. 1521
www.eucertification.com

Name of Manufacture:

BRIG Ltd.

Lozovskaya 88, Dergachy 62303
Shevchenko,317, Kharkov 61033
UKRAINE
www.brig-ribs.com

DANGER LEVELS.

The manual contains warnings, identified as follows:



DANGER

A note like this indicates that there is serious risk, that is likely to cause death or permanent serious injury, if appropriate precautions are not taken.



WARNING

A note like this indicates the existence of risk that may cause death or injury, if appropriate precautions are not taken.



ATTENTION

A note like this indicates reference to the application of safety or environmental protection practices, or draws attention to unsafe behaviour that might cause injury to persons or damage to the craft, its components or the environment.

INTRODUCTION.

This manual was written to help you to use your boat safely. It contains information on the boat, its equipment (supplied or installed), operation and maintenance.



DANGER

Before using your boat, read this MANUAL carefully and ensure that you have understood all the procedures it describes. Before taking command of your boat, be sure to have acquired experience and confidence in its operation.

IDENTIFICATION PLATE.

Builder's Plate:

BRIG RIBS INTELLIGENT RIBS www.brig-ribs.com		CE	
MODEL	Eagle 10	Typ	X
Conforms to EN ISO 6185 - 4		Design Category	B
	2x261 kW 2x350 HP		≤ 12
	2170 kg		4784 lbs
	0.2 bar (2.9 p)	Mar	

Maximum propulsion power rating

Boat Design Category according to Directive 2013/53/EU

Passengers capacity (75kg each)

The rated tube pressure

Manufacturer's recommended maximum load, including the mass of the outboard engine(s) but excluding the mass of the contents of fixed fuel and water tanks when full

Plate with identification number:

UA-QRK12345A000

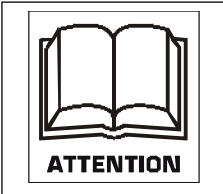

It is fundamental for the plates to be aboard the boat, since they are only form of recognition and identification. Without them the boat does not comply with the legislation in effect. The plates must never be removed. Any tampering or removal not authorised by the manufacturer is the full responsibility of the owner.

BEAUFORT Wind Scale and Corresponding State of the Sea, After Few Hours of Wind, Away From the Coast.

Force	Denomination	Knots	Km/h	m/sec	State of the sea and wave height in meters	
0	Calm	<1	<1	0-0.2	Calm	0
1	Light Air	1-3	1-5	0.3-1.5	Calm	0
2	Light Breeze	4-6	6-11	1.6-3.3	Almost calm	0.2
3	Gentle Breeze	7-10	12-19	3.4-5.4	Almost calm	0.2
4	Moderate Breeze	11-16	20-28	5.5-7.9	Small waves	0.5
5	Strong Breeze	17-21	29-38	8.0-10.7	Large waves	1.25
6	Fresh Wind	22-27	39-49	10.8-13.8	Large waves	2.0
7	Strong Wind	28-33	50-61	13.9-17.1	Very large waves	2.5
8	Gale	34-40	62-74	17.2-20.7	Rough sea	4
9	Strong Gale	41-47	75-88	20.8-24.4	Very rough sea	6
10	Storm	48-55	89-102	24.5-28.4	Heavy	9
11	Violent Storm	56-63	103-117	28.5-32.6	Very heavy	14
12	Hurricane	64 and over	118 and over	32.7 and over	Stormy	14 and over

Boat Design Categories (Directive 2013/53/EU):

Design category	Wind force (Beaufort scale)	Significant wave height
"A" - "Ocean" "B" - "Offshore" "C" - "Inshore" "D" - "Sheltered waters"	exceeding 8 up to, and including, 8 up to, and including, 6 up to, and including, 4	exceeding 4 up to, and including, 4 up to, and including, 2 up to, and including, 0.3

NOTE: **The significant wave height** is the mean height of the highest one-third of the waves, which approximately corresponds to the wave height estimated by an experienced observer. Some waves will be double this height.

SAFETY REGULATIONS.

This manual contains recommendations and basic rules of conduct for using the boat in complete safety. Although it is not possible to offer safety information for all potential situations, in general it is recommended that you :

	Regularly check which safety requirements are in force.
	Maintain the boat and the onboard plants in optimum condition.
	Have the boat inspected by the dealer where it was purchased or by an authorised mechanic at least once every year for your own safety and for maintaining the guarantee.

	Always check weather and seagoing conditions before setting out. For safe navigation, compare the design category of your boat with the table above.
	The boat must be equipped with liferaft(s) to be stowed for the crew limit. If the liferaft is a rigid canister type, it shall be mounted in the cockpit, ready for use. If the liferaft is contained in a soft bag then it may be stowed in a compartment but shall be readily available for use.

	Max number of transportable persones is referred to an established weight of 75 kg per person (ISO 6185), so always make reference to total maximum transportable weight. The max weight of the installable motors indicates the maximum overall weight applicable on the stern board, including any emergency motors. NEVER exceed the stated value.
---	---

ALWAYS REMEMBER ABOUT FIRE DANGER .

Fire may be caused by:

Crew negligence when smoking, the presence aboard of flammable liquids, electrical contacts, propulsion motor, errors in fueling, or if maintenance has not been performed as required.

Once again, it is important that the crew behave correctly and that the boat is kept in order to avoid serious damage to it and to persons.

	Easily flammable products must not be kept aboard.
---	--

	BATTERY: the battery may cause sparks or explosions. It must be stored in an appropriate container, easily reached and well aired, AWAY FROM FUEL OR INFLAMMABLE PRODUCTS . Periodically check that the clips are tight and protect them with appropriate insulation in order to prevent sparks or the spread of current.
---	---

However, if a fire does occur aboard, stop motor, disconnect the batteries immediately, check to see if it is an electrical component or any case a small-scale fire that does not involve flammable liquids, in which case use a suitable fire extinguisher to try and put the fire out completely.

	Extinguisher or any other fire-fighting equipment must not be kept in compartments with key lock, but in easily accessible and clearly indicated locations.
	Extinguisher or any other fire-fighting equipment should be checked periodically and replaced with the same or superior types if expired or inefficient .

	Equip the boat with fire-fighting equipment before launch and use.
--	--

TECHNICAL SPECIFICATIONS.

The basic parameters and dimensions of the EAGLE 10 comply with the data specified in the following table.

All dimension measurements indicated have a tolerance of +/- 3%, weight measurements indicated have a tolerance of +/- 5%.

Parameter		EAGLE 10
Length with / without rear step plates (without engine)	m	10.3 / 9.95
Beam	m	3.40
Height	m	2.30
Inflatable tube diameter, max.	m	0.65
Cockpit dimensions:		
- length	m	7.70
- width	m	2.10
Deadrise angle on transom		22°
Deadrise angle in middle section		27°
Transom height	mm/inches	760 / 30"
Number of independent air-tight chambers	pcs.	7
Nominal pressure	BAR/psi	0.2 / 2.9
Passengers capacity (75kg each)	persons	12
Recommended engine power		2x300 HP
Maximum engine power		2x261kW / 2x350HP
Maximum engines weight (including controls and batteries)	kg	740
Engine(s) shaft length		2x25" (635mm) or 1x30" (762mm)
Weight of empty boat (with steering console, with seats, without engine, without fuel)	kg	2200
Light Craft Condition (LCC) excl.engines	kg	2260
Light Craft Condition (LCC) incl.engines	kg	3000
Maximum total load ML (total weight of the fuel, passengers and cargo onboard)	kg	2000
Maximum recommended load (including weight of the max engines, passengers and cargo onboard, but excluding the mass of the contents of fixed fuel and water tanks when full)	kg	2170
Loaded displacement mass (LDC)	kg	5000

Eagle 10 COMPLETE SET.

In the table below is shown the maximum possible complete set, which may differ from your boat.

1	Inflatable boat	+	27	Battery containers	+
2	Foot pump	+	28	Socket for anchor light	+
3	Paddle	+	29	Mast with anchor light	+
4	Set of spare parts and repair kit	+	30	Front locker removable cushions	+
5	Bag	+	31	Soft cushions of the cabin	+
6	Owner's manual	+	32	Removable bow sundeck	+
7	Valve cap pressure gauge	+	33	Removable rear sundeck	+
8	Steering console	+	34	Removable cockpit table	+
	Steering console equipment:		35	SeaDek set	+
9	Hydraulic steering system	+	36	Collapsible Sun-top	+
10	Steering wheel	+	37	Ski mast	+
11	Fuel level clock	+	38	Rear step-plates with foldable ladder	+
12	Electrical switches with fuses	+	39	Covers for steering console and cushions	+
13	Sockets 12V + USB with fuse	+			
14	Electric horn	+			
15	Running lights (red and green)	+			
16	Front step-plate	+			
17	Fuel system with fuel tank 585 Litres (155 Gal)	+			
18	Drain system with automatic bilge pumps	+			
19	Anchor with electrical windlass	+			
	Shower system:				
20	Water tank (45 litres)	+			
21	Shower handset	+			
22	Shower pump	+			
23	Electrical stationary toilet	+			
	Waste-water system:				
24	Waste tank (55 litres)	+			
25	Pump with macerator	+			
26	Kitchen sink with water tank (39 litres)	+			

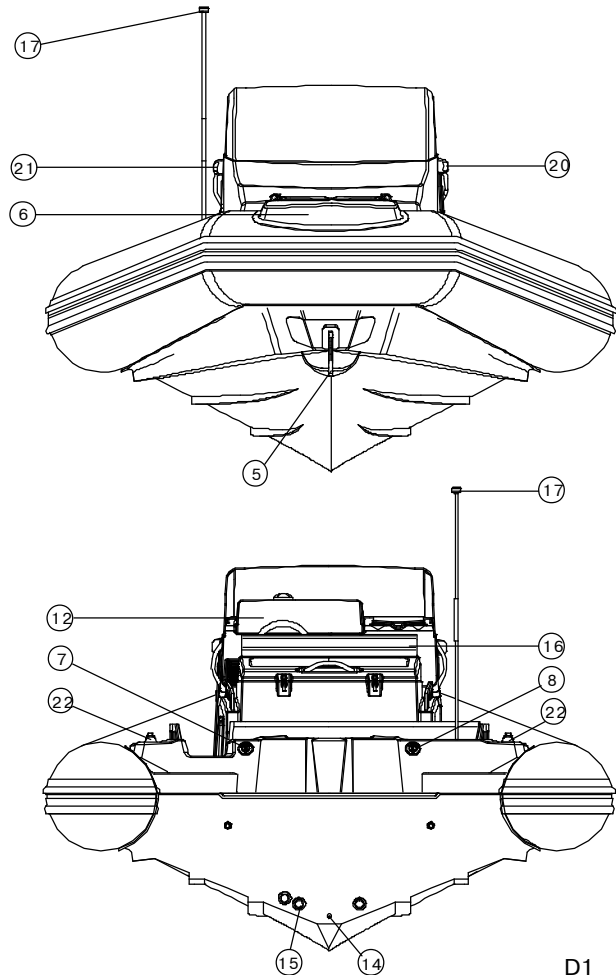

BOAT DESIGN.

The boat series "EAGLE" Eagle10 consists of the next main components, (Fig. D1):

- polyester hull (1);
- reinforced buoyancy tube (2);
- steering console (12);
- driver and passenger seat (16).

●DESCRIPTION:

- 1 — Polyester hull.
- 2 — Reinforced buoyancy tube.
- 3 — Doubled rubbing strake.
- 4 — Safety handle.
- 5 — Anchor.
- 6 — Bow step-plate with two bow cleats and soft cushion.
- 7 — Neck for fuel fill.
- 8 — Neck for water fill.
- 9 — Box with cap for shower handset.
- 10 — Steering console seat.
- 11 — Air fill valve (7 pcs.).
- 12 — Steering console.
- 13 — Front locker removable cushions.
- 14 — Drain plug.
- 15 — Cockpit drain system socket (3 pcs.).
- 16 — Driver and passenger seat.
- 17 — Anchor light (white).
- 18 — Stern-part seat.
- 19 — Soft back of stern-part seat.
- 20 — Port running light (red).
- 21 — Starboard running light (green).
- 22 — Two stern-part cleats.
- 23 — Outlet on the deck for clearing waste tank.

D1

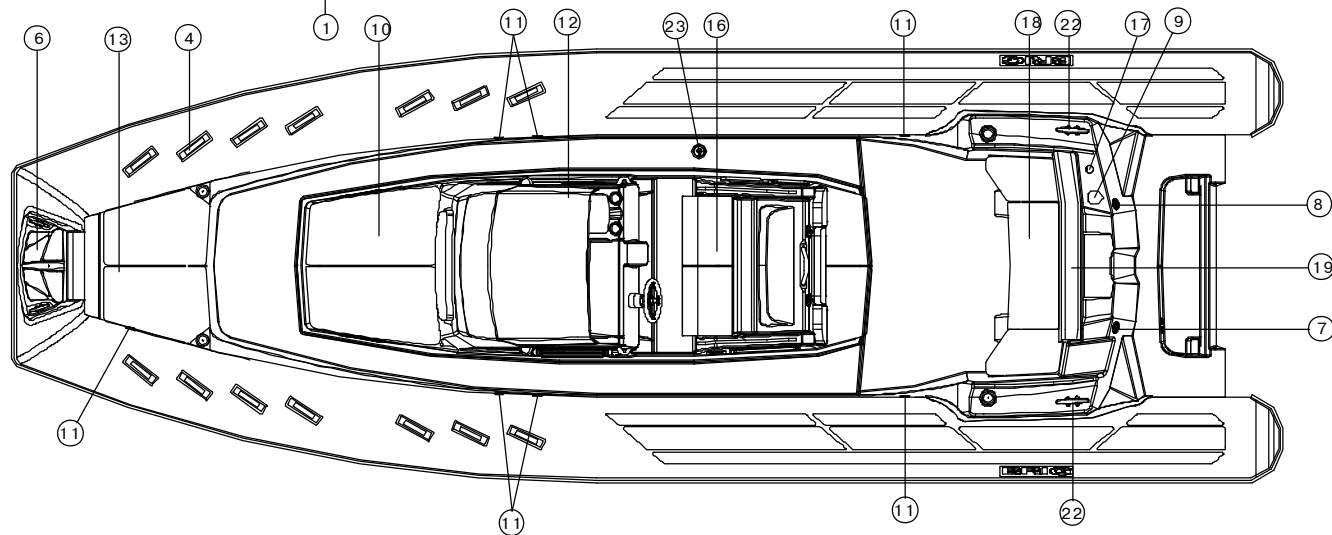
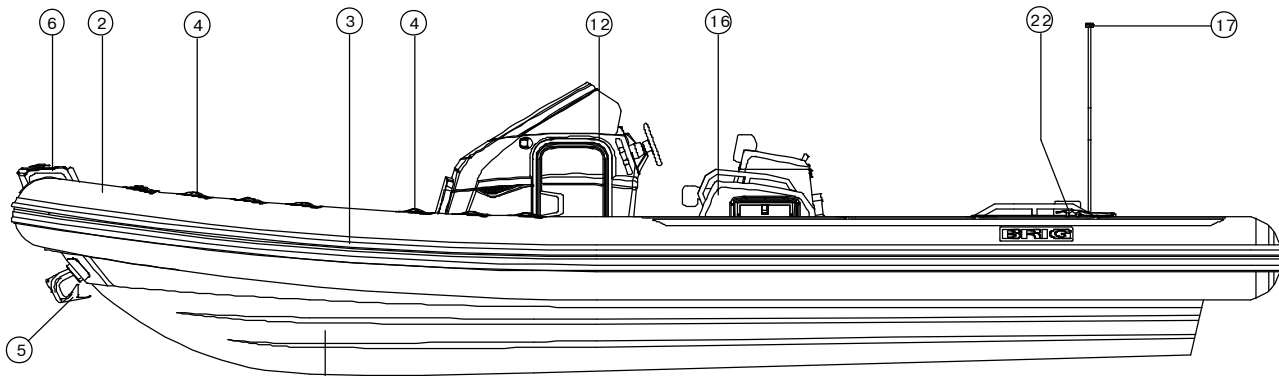

●RIGID HULL.

The boat hull has "deep-V" shaped bottom with four longitudinal steps.
There are six specified sections (Fig. D2):

- bow anchor locker (1) is intended for arrangement of anchor system and anchor chain/rope;
- cabin with stationary toilet in the interior part of steering console (2);
- the interior part of driver seat is intended for arrangement of fridge, water tank, kitchen sink and/or cooking panel (3);
- the under-deck compartment for system of collecting and removal of waste water (4);
- the under-deck compartment for fuel tank (5);
- stern compartment for drain systems, bilge pumps, shower system (6).

The boat hull is arranged with the following components:

- bow towing eye (7);
- place for baggage (8);
- place for table (9);
- stationary toilet (10);
- tank for collecting waste-water (11);
- water tank (12);
- fuel tank (13);
- drain automatic bilge pumps (14);
- anchor control buttons ("UP"/"DOWN") (15);
- two stern cleats (16);
- socket for anchor light (17);
- box with cap for shower handset (18);
- neck for water fill (19);
- neck for fuel fill (20);
- horn (21);
- water tank drainage (22);
- (23);
- inspection hatch (24);
- gas bottle hatch (25).

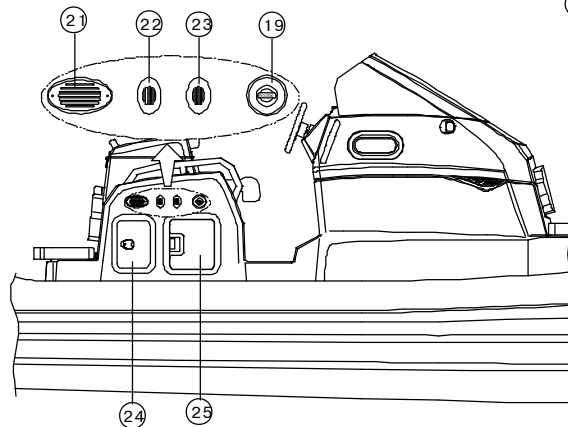
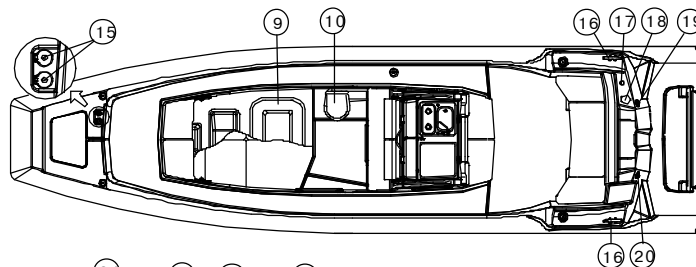
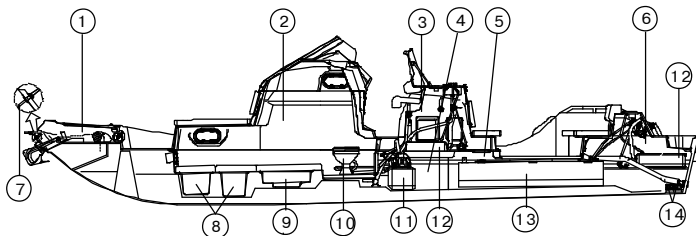

D2

There is also three-position battery disconnecter located in the stern compartment and one more battery disconnecter under the driver seat. The fore and stern parts of the cockpit may be simply converted into the sundeck by means of false decks and soft cushions.

●REINFORCED BUOYANCY TUBE.

The boat buoyancy tube has U-shaped form. The tube is separated by means of inner elastic partitions into seven chambers of a similar volume, each being provided with an air fill valve.

The air fill valve is intended for:

- filling the compartment with air from a standard pump or filling system and maintaining pressure in the tube for prolonged time,
- adjustable drop of pressure in compartment.

The air fill valve is designed as a tab-type non-return valve and consists of the following components (Fig. D3):

- housing (1);
- cup (2) with strap (3);
- washer with gasket (4);
- nut (5);
- spindle (6) with spring (7) and cup diaphragm (8).

Also there are the following elements fitted on the tube (Fig. D1):

- doubled rubbing strake (3, Fig.D1);
- safety handles (4, Fig.D1);
- bow step-plate with two bow cleats and soft cushion (6, Fig.D1).

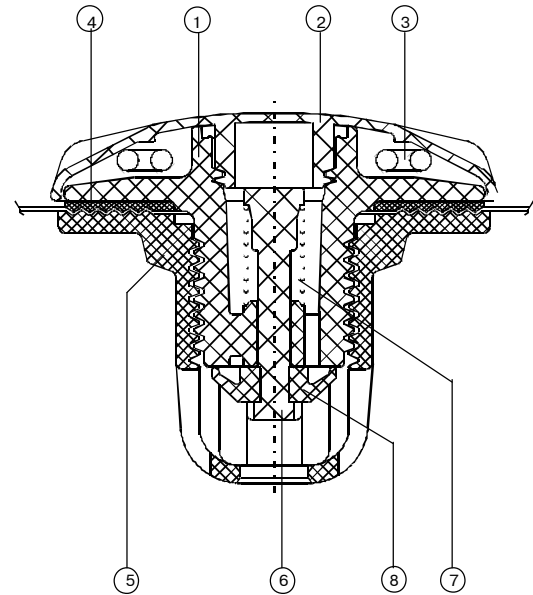

D3

●STEERING CONSOLE

The console consists of the following components (Fig. D4):

- console body (1) is installed onto the console base (2), which is installed on the boat deck;
- windscreen (3);
- front seat (4);
- soft seat-back;
- door with lock for access to the cabin (5).
- console recess with glass cap (6);
- small recesses (7);
- glass holders(8);
- stainless steel handrail (9);
- portlight (3 pcs.) (10).

Console equipment (Fig. D5):

- hydraulic steering system;
- steering wheel (1);
- compass (2);
- socket 12V with fuse (3);
- fuse holding box with warning lights(see D5) (inside of the steering console);
- switch panel (4).
- **switches:**
 - horn switch (5);
 - running lights and meter lamp switch (6);
 - anchor light switch (7);
 - bilge pump 1 switch (8);
 - bilge pump 2 switch (9);
 - shower pump switch (10);
 - panel backlight switch (11);
 - reserve switch 1 (12);
 - reserve switch 2 (13);
 - reserve switch 3 (14);

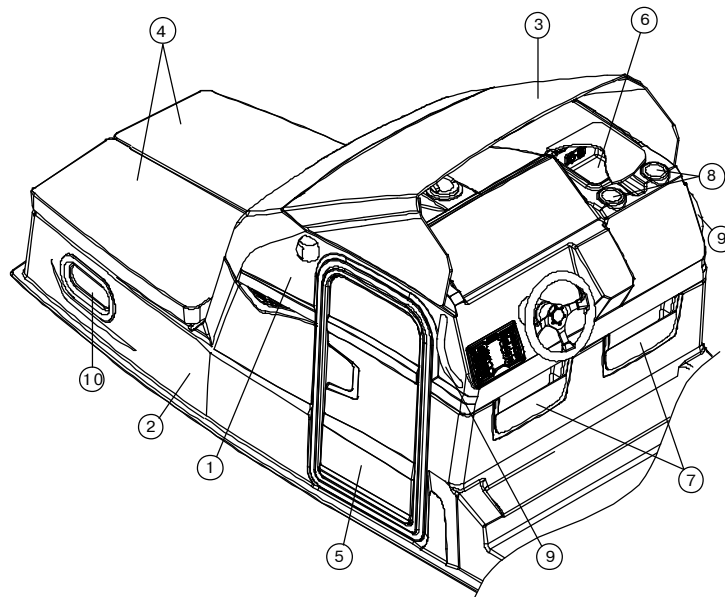

D4

Fuse holding box with warning lights

1	10A			10A	6
	HORN	○	○		BILGE PUMP 1
2	5A	○	○	10A	7
	RUNNING LIGHTS				BILGE PUMP 2
3	5A	○	○	5A	8
	ANCHOR LIGHT				SHOWER PUMP
4	5A	○	○	10A	9
	PANEL BACKLIGHT				12 V SOCKET
5	5A	○	○	10A	10
	AUX 1				12 V SOCKET

1	15A	○	○	5A	6
	MACERATOR PUMP				CABIN LIGHT
2	25A	○	○	10A	7
	TOILET PUMP				AUX 2
3	10A	○	○	5A	8
	KITCHEN PUMP				AUX 3
4	15A	○	○	5A	9
	FRIDGE				AUX 4
5	5A	○	○	5A	10
	AUX 1				AUX 5

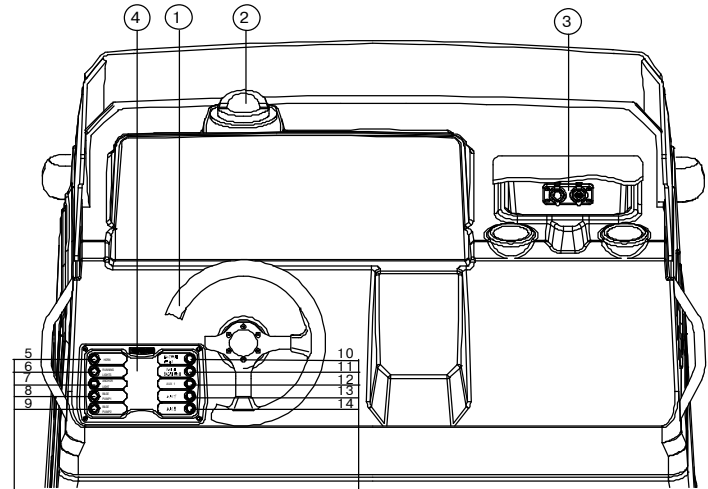

5 HORN (10A)

10 SHOWER PUMP (5A)

6 RUNNING LIGHTS (5A)

11 PANEL BACKLIGHT (5A)

7 ANCHOR LIGHT (5A)

12 AUX 1 (5A)

8 BILGE PUMP 1 (10A)

13 AUX 2 (10A)

9 BILGE PUMP 2 (10A)

14 AUX 3 (10A)



Always check the fuse. Burning red LED display on the fuse box warns of faulty fuse

Always keep a spare set the fuse in an easily-accessible location.

●THE CABIN.

Inside the cabin there is (Fig. D6):

- place for sleep with soft cushions(1);
- portlights (3 pcs.) (2);
- place for baggage (3);
- special place for keeping bow sundeck boards, cockpit table, table legs (4);
- small recesses with 12V and USB sockets (5);
- stationary toilet (6).

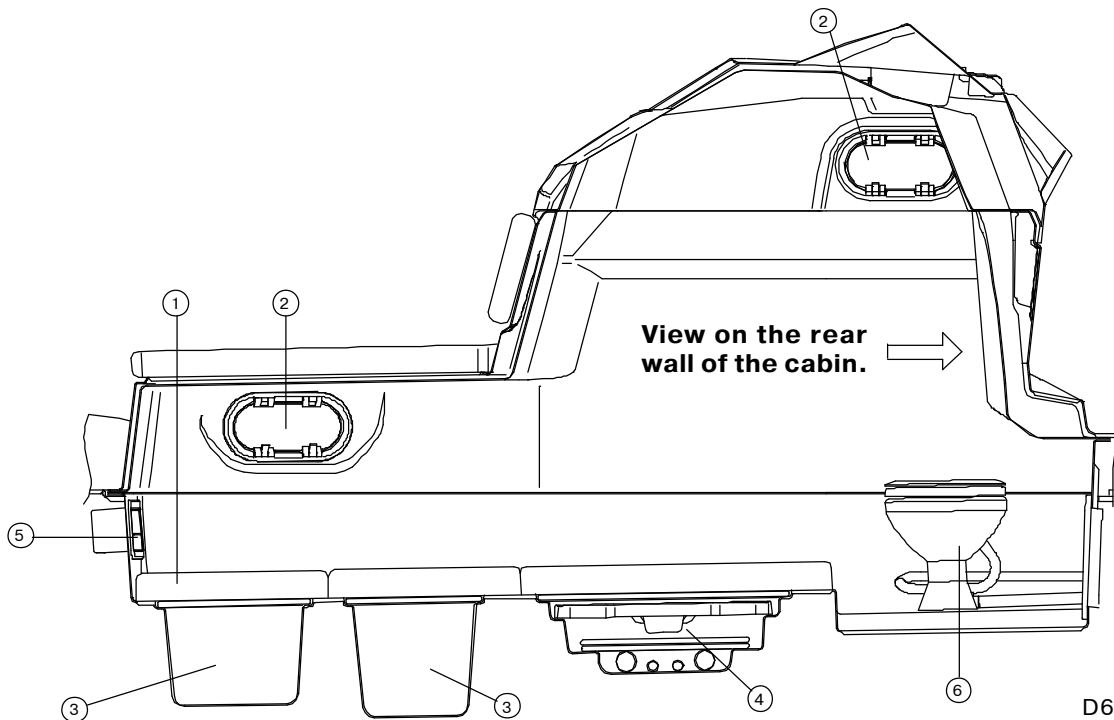

D6

Inside the cabin there is (Fig. D7):

- hatch with the fuse holding box with warning lights inside (1);
- additional switch panel for switching kitchen pump, fridge and waste pump (2);
- the hatch for access to faucets 1 and 2 (for water intake for toilet and for pumping waste water from waste tank into the sea) (3);
- stationary toilet (4);
- toilet control panel (5);

View on the rear wall of the cabin.

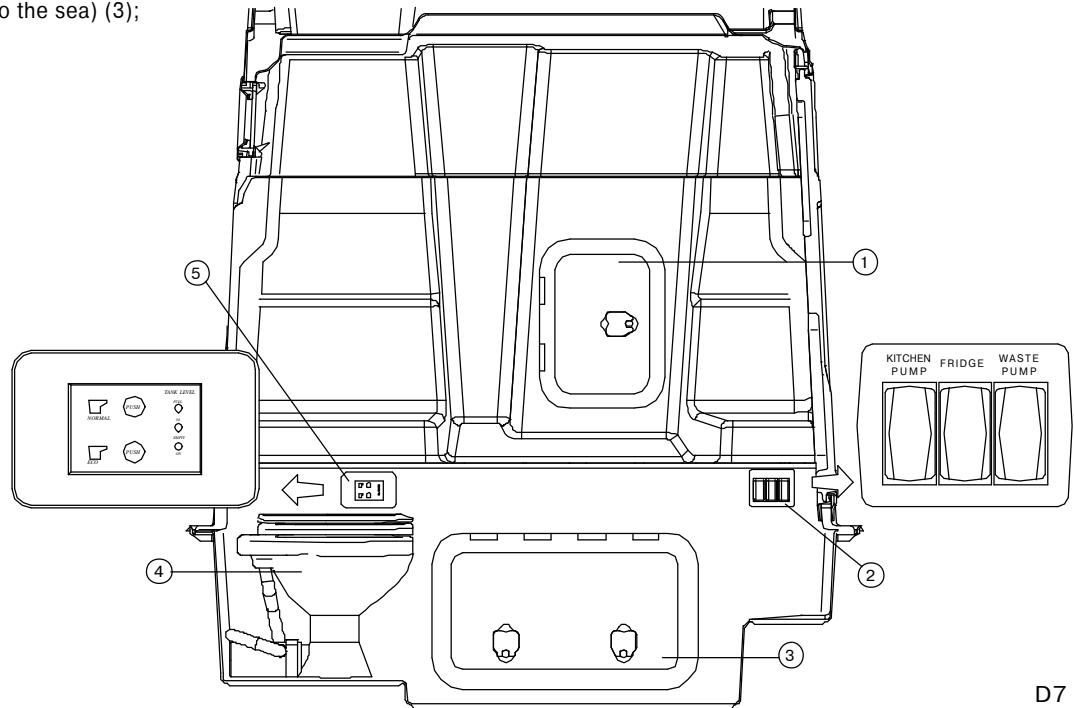

●WASTE-WATER SYSTEM.

Waste-water system consists of the following components (Fig. D6):

- faucet **1** for water intake for toilet (1);
- faucet **2** for pumping waste water from waste tank into the sea (2);
- faucet **3** for kitchen sink (3);
- waste tank (4);
- pump with macerator for pumping waste water from waste tank into the sea (5);
- toilet pump with macerator for for water intake and for pumping waste water from toilet into the waste tank (6);
- outlet on the deck for clearing waste tank (7);
- siphon (8);
- kitchen sink (9);
- sanitary hose (from kitchen sink to waste tank) (10);
- sanitary hose (from faucet **1** to toilet pump with macerator) (11);
- sanitary hose (from toilet pump with macerator to waste tank) (not shown);
- sanitary hose (from waste tank to pump with macerator) (12);
- sanitary hose (from pump with macerator to faucet **2**) (13);
- sanitary hose (from waste tank to the outlet on the deck) (14);
- waste tank drainage outlet (15);
- waste tank drainage filter (16);
- waste tank drainage hose (17);

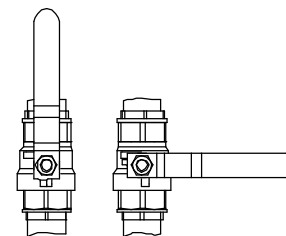

OPEN

CLOSED



All faucets must be closed, when toilet and waste -water system are not in use.

STARBOARD OF THE BOAT

PORT SIDE OF THE BOAT

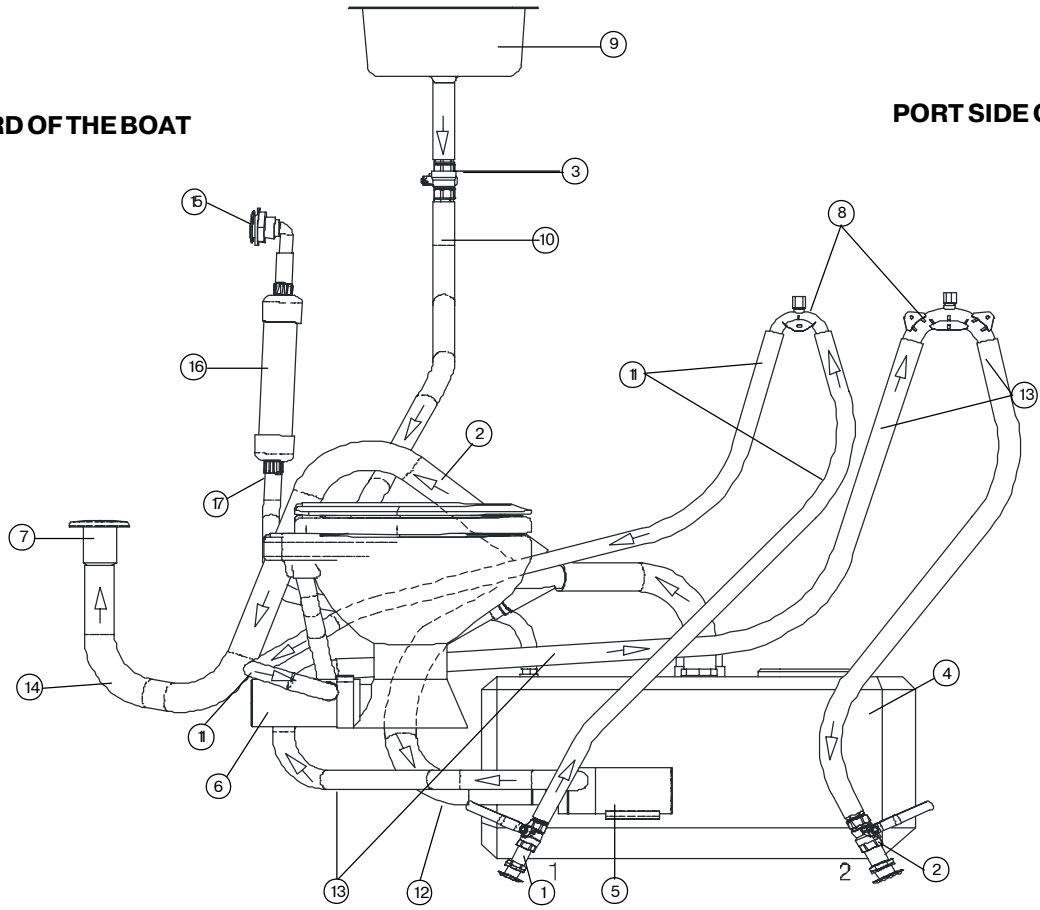

D8

HOW TO USE THE TOILET AND WASTE-WATER SYSTEM.

Before using the toilet, please open big hatch (3, Fig. D7) inside the cabin, open faucet **1** (1, Fig.D8). For washoff the toilet, please use the toilet control panel (5, Fig. D7). After using the toilet, please close faucet **1** (1, Fig. D8).

Before using the kitchen sink, please open inspection hatch (24, Fig. D2) on the starboard of the driver seat, open faucet **3** (3, Fig.D8). Switch on the button "KITCHEN PUMP" on additional switch panel inside the cabin (2, Fig. D7) . After using the kitchen sink, please switch off the button "KITCHEN PUMP" on additional switch panel (2, Fig. D7) and close faucet **3** (3, Fig. D8).

When waste-water level gauge on the toilet control panel (5, Fig. D7) shows "full" - it is time to clear waste tank. You may clear waste tank using outlet on the deck for clearing waste tank (23, Fig. D1), (7, Fig. D8). Also You may clear waste tank in the sea, (if Your boat is in the place where is not forbidden to drain off waste-water). In this case, please open big hatch (3, Fig. D7) inside the cabin, open faucet **2** (2, Fig.D8). Push the button "WASTE PUMP" on additional switch panel (2, Fig. D7). When waste tank is empty, switch off the button "WASTE PUMP" on the switch panel (2, Fig. D7), after that, please close faucet **2** (2, Fig.D8).

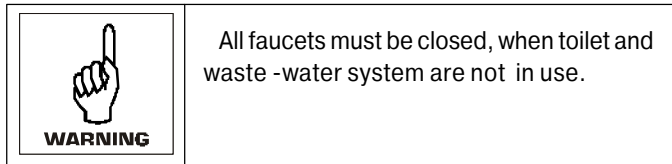

●SHOWER SYSTEM.

Shower system includes the next components (Fig. D9):

- water tank (1);
- neck for water fill (2);
- shower pump (3);
- box for shower handset (4);
- shower handset with push button control and shower hose (5);
- hose for venting water tank (6);
- water hose (from neck for water fill to tank) (7);
- water hose (from water tank to shower pump) (8);
- shower hose (from shower pump to shower handset) (9).

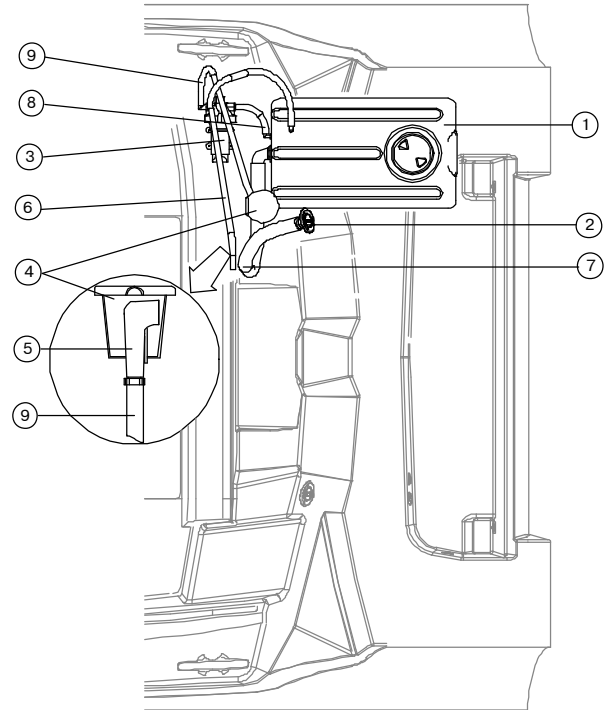

D9



It is dangerous to pretend to be an expert. This may cause damages. Refer to expert and authorized specialists for all types of maintenance and repair.

● FUEL SYSTEM.

Fuel system consists of the following components

(Fig. D10):

- built-in fuel tank 585L (155gal) (1);
- electric fuel gauge (2);
- outer neck for fuel fill (3);
- fuel hose (from outer neck for fuel fill to fuel tank) (4);
- fuel hose (from fuel tank to outboard motor) (5);
- fuel venting hose (6).

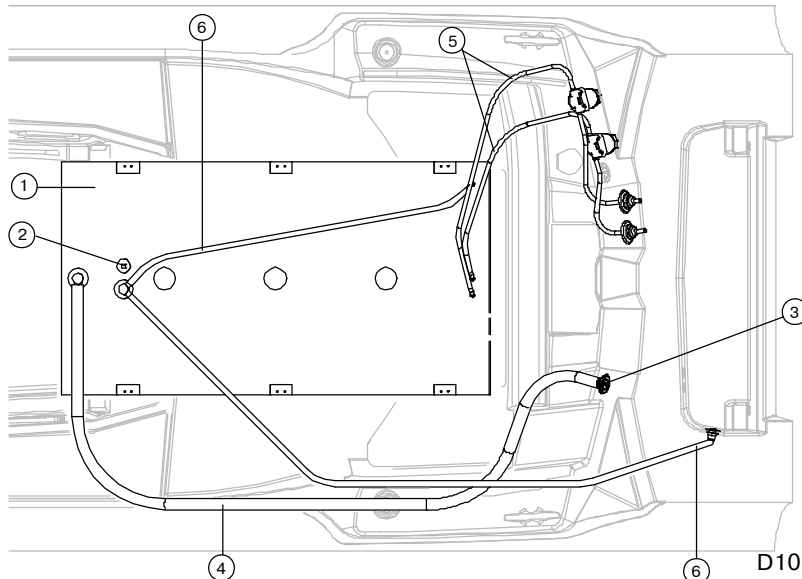

DANGER

Pre-filter and fuel valve must be installed by authorized representative specialists only.

Do not modify fuel system. Any modification, repair and planned maintenance of the fuel system may be made by authorized representative specialists only.

Check that there are no leaks in the fuel systems



WARNING

Do not smoke when refueling. Stop the engine and switch off any electric equipments before refueling.

●DRAIN SYSTEM.

Drain system, (Fig. D11), consists from two independent systems:

- drain system of the cockpit and motor recess ;
- drain system of the hull.

DRAIN SYSTEM OF THE COCKPIT AND MOTOR RECESS includes:

- three cockpit drain sockets (1);
- three stern drain sockets with flexible diaphragms (2);
- three drain hoses (3);
- two drain sockets thru-hull out of motor recess (4);

DRAIN SYSTEM OF THE HULL includes:

- two automatic bilge pumps (5);
- two drain hoses (6);
- two drain sockets installed in the motor recess (7);

WHEN BOAT ON WATER.

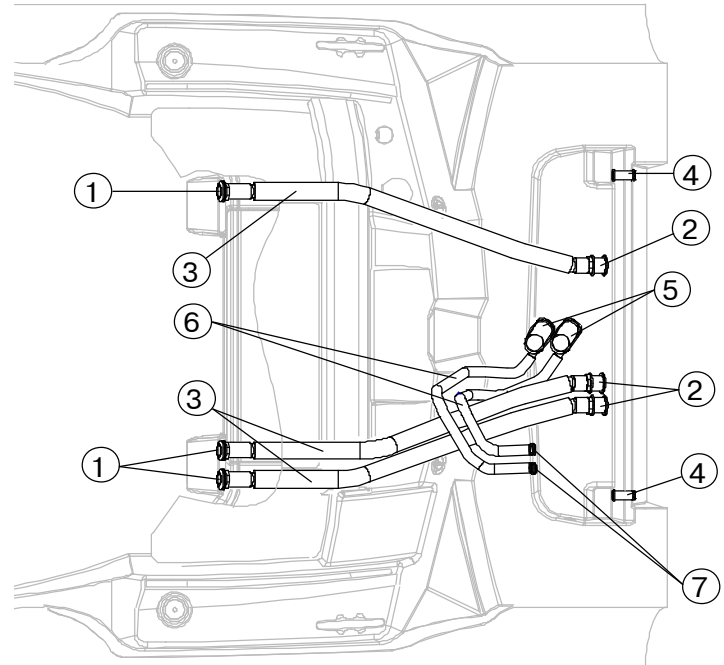

D11



ATTENTION

Periodically clean out all the drain openings and bige pumps from dirt.



WARNING

Always the cockpit drain sockets must be open during navigation. Do not obstruct cockpit drain sockets at any time. Do not dispose bulky objects in front of the cockpit drain sockets.

Before navigation check the drain sockets. **DRAIN PLUG (14) (Fig.D1) MUST BE TIGHTLY CLOSED WHEN BOAT ON WATER.**

Never locate heavy objects on the drain hoses. It will be cause of bucking, distortions and damages.

●ANCHOR SYSTEM.

Anchor system (if included to the complete set) is located inside the bow anchor locker (Fig. D12).

Anchor system includes the next components:

- anchor (1);
- electrical anchor windlass (2);
- roller (3);
- anchor windlass switch buttons: "Up" and "Down" (4);
- windlass circuit breaker (5) (on some versions mounted on the steering console under the steering wheel);
- windlass control box (6) (on some versions is installed inside the driver's seat);
- anchor chain and rope (7);
- safety pin (8);

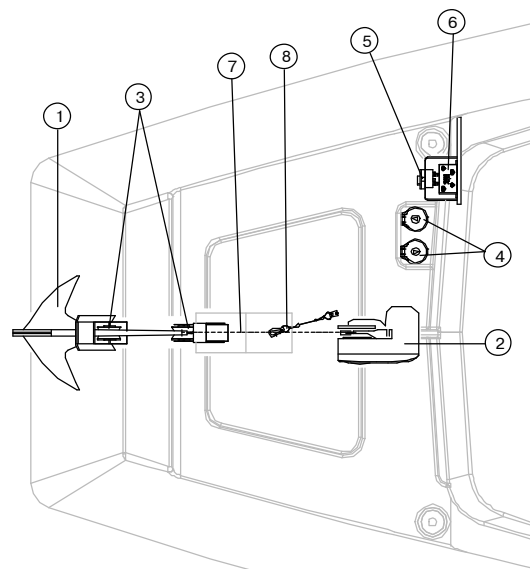
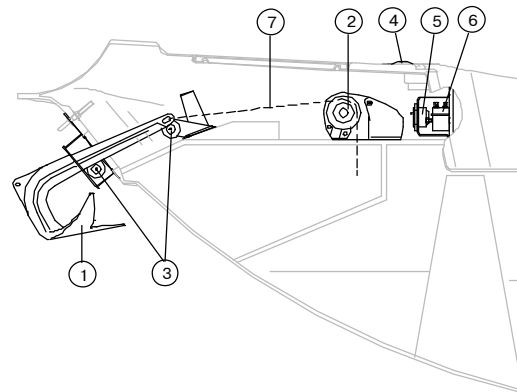

D12

BRIG

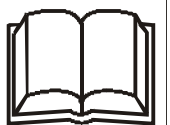

ATTENTION

Before beginning to operate with anchor system, carefully study the owner's manual for electric windlass.



WARNING

Periodically check that the special anchor shackle are tightened correctly.

●HOW TO OPERATE WITH ANCHOR SYSTEM.

Before beginning to operate with anchor system, carefully study the owner's manual for electric windlass . Please, respect all requests and follow all instructions stated in above indicated manual.

If you need to drop/cast the anchor by electric motor:

- 1.Disconnect battery disconnecter.
- 2.Open the bow anchor hatch. By means of handle (from the windlass complete set) close the windlass clutch nut.
- 3.Disengage safety pin (8) from chain.
- 4.Switch on windlass circuit breaker (5) and then battery disconnecter.
- 5.By means of anchor windlass switch buttons: "Up" and "Down" (4) drop/cast the anchor.
- 6.Switch off the main battery disconnecter. Close the bow anchor hatch.

If you need to stow the anchor by electric motor:

- 1.Disconnect main battery disconnecter.
- 2.Open the bow anchor hatch. By means of handle (from the windlass complete set) close the windlass clutch nut.
- 3.Check that the safety pin (8) is detached from chain.
- 4.Switch on windlass circuit breaker (5) and then battery disconnecter.
- 5.By means of anchor windlass switch buttons: "Up" and "Down" (4) begin to stow the anchor.
6. When the anchor will begin to crawl on a roller, stop windlass electric motor in order to see that the anchor is not swinging and have occupied correct position. CHECK, THAT THE ANCHOR OCCUPIED CORRECT POSITION (Fig. D13).
- 7.Continue to stow the anchor, until it will be fixed on a stemhead roller.
- 8.Switch off windlass circuit breaker (5) and then battery disconnecter.
- 9.Hook safety pin (8) to the chain. Close the bow anchor hatch.

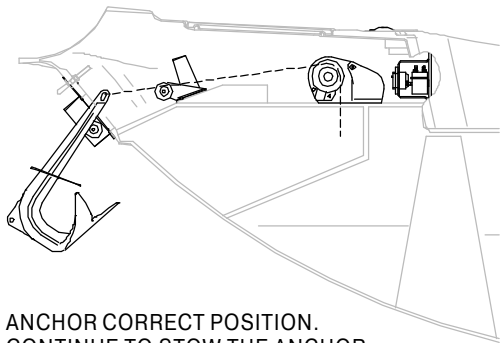

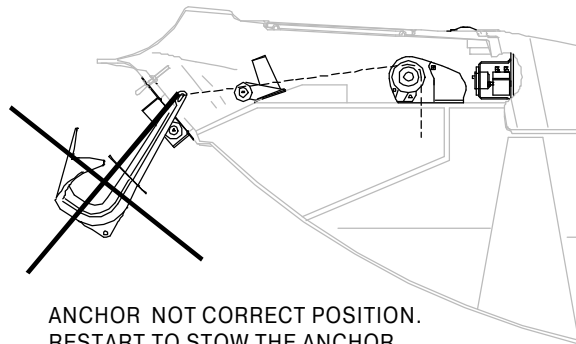

ANCHOR CORRECT POSITION.
CONTINUE TO STOW THE ANCHOR.

D13



ANCHOR NOT CORRECT POSITION.
RESTART TO STOW THE ANCHOR.

 WARNING	<p>CHECK, THAT THE ANCHOR HAVE OCCUPIED CORRECT POSITION AND ONLY AFTER THAT CONTINUE TO STOW THE ANCHOR.</p> <p>Safety pin must always been hooked to the chain when the windlass is not in use.</p> <p>Do not use the windlass for different purposes it was designed for.</p>
 WARNING	<p>Always turn off the windlass circuit breaker when the windlass is not in use to prevent any accidental engagement.</p> <p>Always keep hands and feet off an operating windlass. If the chain gets blocked, turn the windlass off and try to free the chain extremely carefully.</p>
 ATTENTION	<p>Check that the chain was not twisted in the area between the anchor and the windlass. Untwist it, if necessary.</p> <p>Periodically clean out the drain opening from dirt.</p>

●STORAGE BATTERIES INSTALLATION.

In order to install the storage batteries, perform next operations:

- open door of the stern compartment;
- open inspection hatch on the back side of the driver seat;
- install the storage batteries into the batteries containers;
- connect the battery terminals with electrical cords and battery disconnectors;
- please, check efficiency of the electric equipment.



WARNING

Before installation your storage battery read the BATTERY MANUAL carefully and ensure that you have understood all the described procedures.



WARNING

Do not modify electrics of the boat.
Any modification, repair and planned maintenance may be made by authorized representative specialists only.

Do not touch the electrical equipment with wet hands.

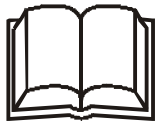

ATTENTION

When leaving the boat, remember to disconnect the batteries.

●HOW TO INSTALL A TABLE.

There is special place in the rear part of the deck, intended for mounting the table. In order to install the table, please perform the next operations (Fig. A14):

- please, screw two legs of the table into the table basises;
- please, put on the flanges of the table onto the table legs.

In order to remove the table, please perform the next operations:

- please, take off the flanges of the table from the table legs;
- please, push the buttons on the table basises and unscrew two table legs from the table basises;
- please place the table with the table legs into the special place for table storage, inside the cabin, (4, Fig. D6).

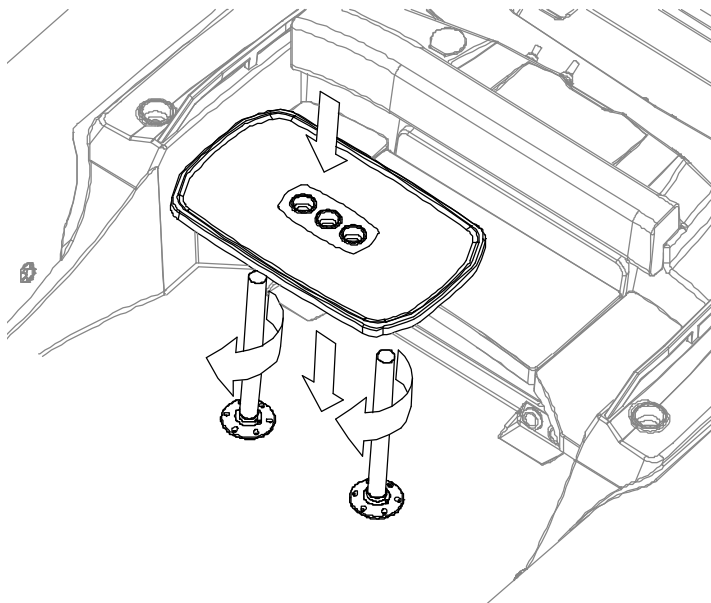

A14



The speed of the boat with installed the table can not exceed 7 km/h (4 knots)
Fold the table before the start boat is moving

●HOW TO INSTALL BOW SUNDECK.

Bow sundeck set includes two false deck boards and two soft cushions. In order to install the sundeck (Fig. A15), please do the next:

- Insert one of the boards of the false deck into the special groove between the front seat of the steering console and the console base part. Align and insert the opposite part of the board into the special drop in the front wall of the cockpit (Fig. A15a).
- In the same way, please install the second board.
- Further, please place two soft cushions onto the false deck and fasten them with the help of press-buttons (Fig. A15b).

two false deck boards:

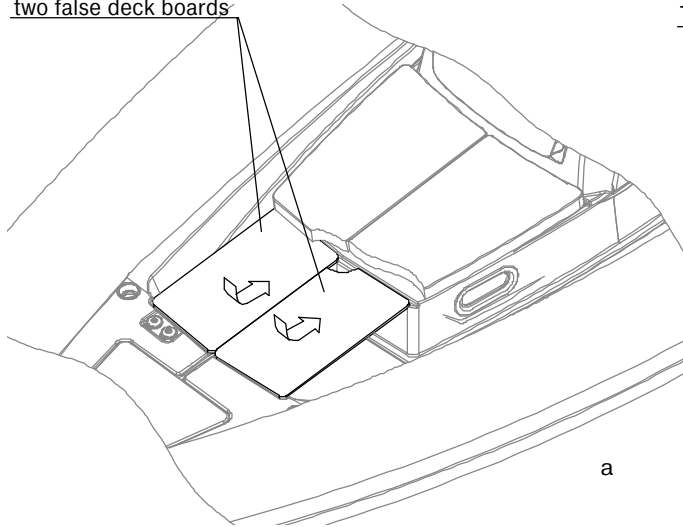

Two soft cushions

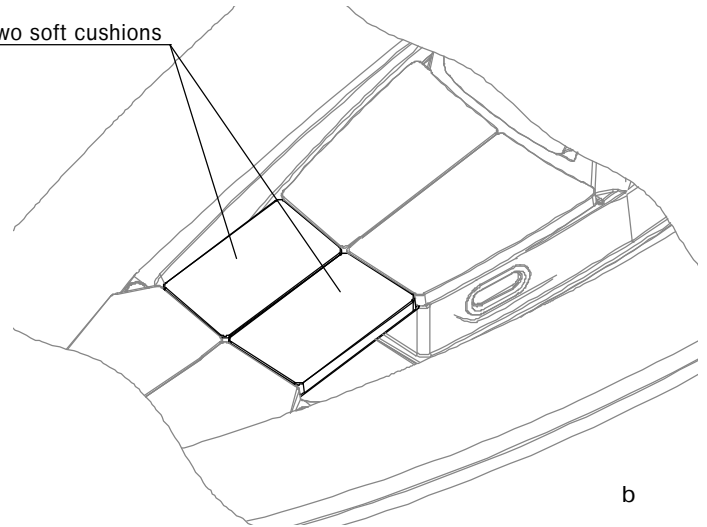

A15



ATTENTION

Always check fixation of the sundeck cushions.

●HOW TO INSTALL REAR SUNDECK.

Rear sundeck set includes two sundeck bearings, two false deck boards and two soft cushions. In order to install the sundeck (Fig. A16), please do the next:

- Please, open rear seats of the driver seat.
- Please, screw two sundeck bearings into the table bases (Fig. A16a).
- Please, insert one of the boards of the false deck into the special groove between the stern-part seat and the stern-part seat polyester basis. Aline and insert the opposite part of the board into the special drop under the rear seat of the driver seat (Fig. A15b).
- In the same way, please install the second board.
- Please, close rear seats of the driver seat.
- Further, please place two soft cushions onto the false deck and fasten them with the help of press-buttons (Fig. A15c).

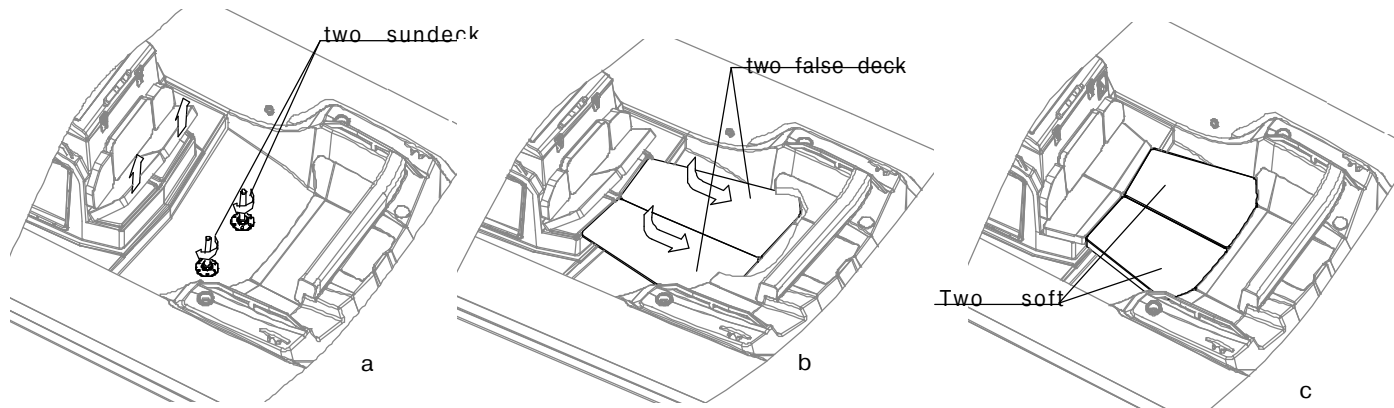



●INFLATION/DEFLATION OF THE BOAT TUBE.

The inflatable tube of the boat has seven independent air-tight chambers. Before inflation it's necessary to set all valves in operating condition. In order to switch valve in operating condition, please press spindle 6 (Fig. D3) with your finger and rotate it clockwise until the spindle will be fixed. If this operation isn't possible, it means the valve already has been set in operating condition.

Fill the tube with air using the pump from the complete set. First fill two rear chambers, next four middle chambers. However, do not increase the pressure up to its operating value (the tube will be completely straightened). After that, please fill the fore chamber up to the rated pressure. **The rated pressure value is 0.2 bar (2.9 psi).** Having completed filling, close the valve covers.

In order to discharge air from the tube chambers, open the valves (please press spindle 6 (Fig. D3) with your finger and rotate it anticlockwise until the spindle will be fixed).

	Do not use compressors and/or other types of inflating equipments not approved by the boat builder.
	Check the tube pressure before every navigation.
	The rated pressure value is 0.2 bar (2.9 psi). If the tube pressure more than nominal, deflate the tube slightly. Boat exploitation with board pressure more than nominal decreases boat service life.

	Board air chambers are hermetical if they keep own form during 8 hours. In this case: <ul style="list-style-type: none">- primary pressure has to be nominal;- input valves openings have to be tightly closed by caps.
---	--

BOAT TRANSPORTATION BY TRAILER.

Installed on a trailer (or on keel-blocks for storage) the boat should be laying on all surface of the **Main loading area (keel line)** (see Fig. T1).

It is possible to install the boat on eight reference points as minimum. Thereby the points of support (1), (2), (3), (4), (5), (6), (7), (8) must be an obligatory, and the any other points of support must be an additional.

Lateral roller supports can be used only with a view of prevention from tipping.

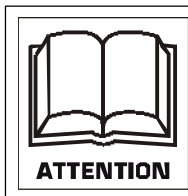
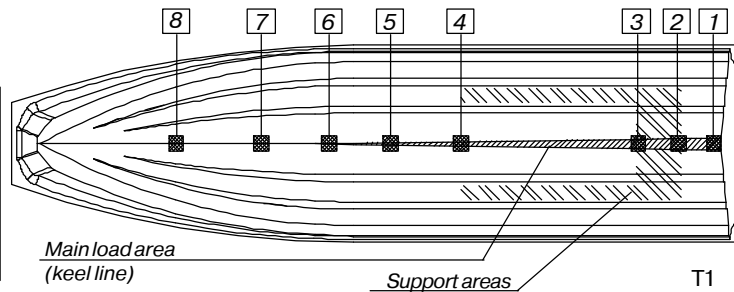
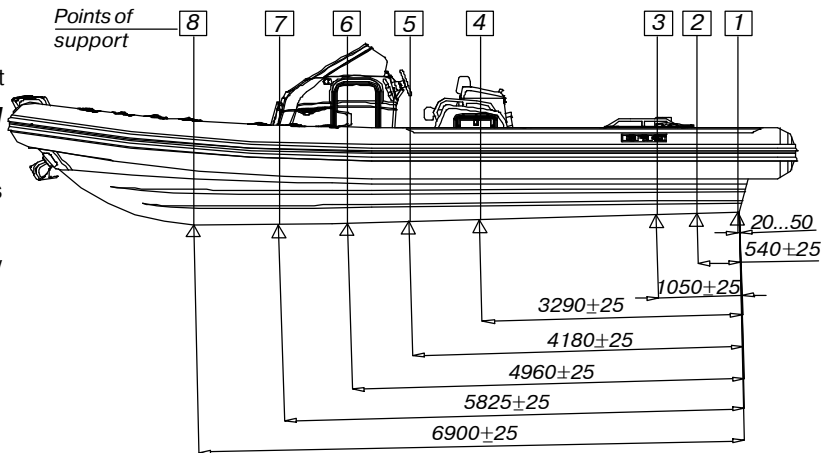

**Maximum transportable mass:
4100 kg**

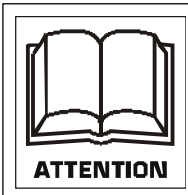

In order to avoid the hull damage, install the boat on the stated areas only.

MAINTENANCE.

- Main conditions of long service life is right and careful servicing. Avoid excessive increasing of pressure in the board, especially from heating by the sun rays.
- At the end of exploitation take off sand and dirt from boat surface, and carefully dry it.
- Avoid the water getting into the chambers. If a fuel or an oil gets to the boat surface it is necessary to wash the soiled place by soap water as soon as possible and dry.
- Pay attention to the condition of bottom surfaces. If the cover is destroyed it is necessary to dry this element and restore the defend cover.
- At the end of the season exploitation, prepare the boat to winter keeping. Clean boat surface from sand and dirt, and make the necessary repairs, if damages take place. If it is possible, keep the boat in open and slightly pumped state at air temperature 0-25°C. The boat must be protected from the sun rays.
- Insignificant boat repairing (eliminating the board punctures or cuts) you may carry out by yourself. In this case use the coated fabric and glue set for repair from the complete set.

The own fulfilment of any complex repair associated with considerable damages to the board, partitions and seams is not recommended. In such cases, apply to your dealer.

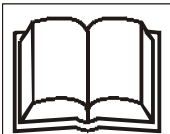

ATTENTION

Storage of the boat with temperature variations from -30°C to +45°C may be allowed not longer than 1 month. In case the boat has been stored or transported at a temperature below 0°C, it must be kept at a temperature above +15°C at least for 1 hour before to be unpacked and unfolded.

For small repair boat tube use the coated fabric and glue set from the complete set.

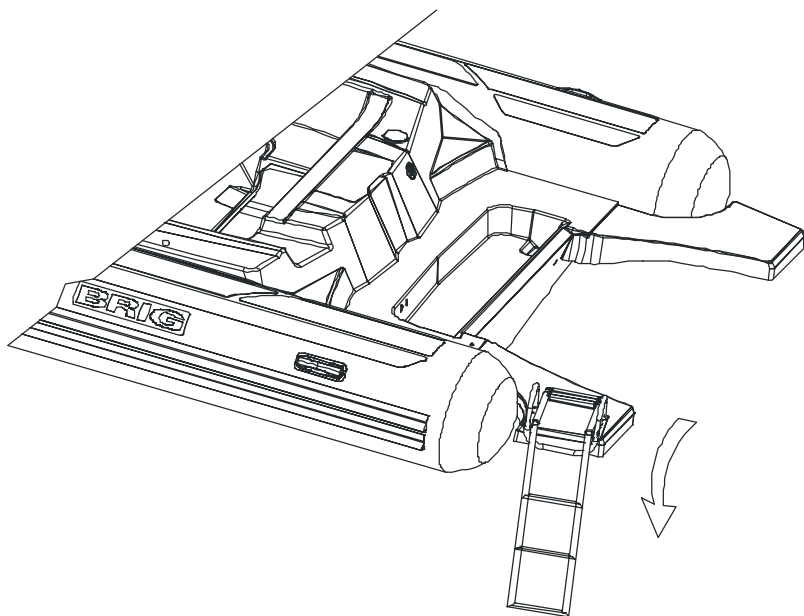

REBOARDING MEANS.

Reboarding ladder mounted on the stern of the boat on the starboard side.

If you are in the water, and the ladder is folded, you can lay out it and return onboard.

The ladder can be fixed with Velcro. Just unclip it.







Be careful -
the rotating propeller on
the engine

OPERATING REGULATIONS.

Dear ownwr,

We thank your for your purchase and do hope that you will have a great fun of it. However, to make your joy and pleasure complete, we would request you to read carefully and observe the directions and recommendations specified below.

	<p>IT IS STRICTLY FORBIDDEN to handle the boat in the state of intoxication and without individual rescue means being used (life-saving belts, jackets, etc.)</p>
	<p>IT IS FORBIDDEN to use an outboard motor of power exceeding the maximum allowable value</p>
	<p>IT IS FORBIDDEN to bring the tube pressure up to the value exceeding the rated one(0.2 bar(2.9psi))</p>
	<p>IT IS STRICTLY FORBIDDEN to drag the boat across a rough surface.</p>
	<p>For each particular water area the local shipping regulations are in force. You may apply for information to the appropriate water transport and shipping directorate, as well as to the water police.</p>
	<p>Use the boat equipment and accessories only on their direct purpose to ensure reliable service.</p>
	<p>Even when sailing with an outboard engine you should always have the oars available with you so that you were able to reach the shore without outside assistance in case of any damage of the boat.</p>
	<p>On your request any outboard engine seller may provide your engine with the emergency stop switch. During navigation the switch should be connected to the wrist of your hand by means of a cord. In case you fall overboard, even if being a steersman, the switch will cut out the engine and the propeller. This arrangement will enable you to avoid any traumas and to reach the boat.</p>
	<p>Take all possible precautions against penetration of fuel, oil or electrolyte from the storage battery into the inflatable boat. If it does happen wash thoroughly the fouled spots with water.</p>



DANGER

You should be always sure that the number of people on board never exceeds that specified in the owner's manual or on the builder's plate provided on the transom.

The boat will retain an adequate floatability and will not keel over only provided that the load is arranged reasonably. **Therefore, do not accommodate all passengers on the same side of the boat.**



DANGER

All passengers should be accommodated inside the boat. The occupied seats should not be left throughout the entire sailing time.



DANGER

All passengers should put on life-saving jackets.

CHILDREN and non-swimmers MUST WEAR A FLOATATION DEVICE AT ALL TIMES.

Always check that floatation devices for children are of the right size and that they are operational.



DANGER

The boat must be equipped with liferaft(s) to be stowed for the crew limit. If the liferaft is a rigid canister type, it shall be mounted in the cockpit, ready for use. If the liferaft is contained in a soft bag then it may be stowed in a compartment but shall be readily available for use.

Liferaft not supplied by the manufacturer and must be installed by owner.



DANGER

Arrange the cargo to be carried uniformly inside the boat, all items being reliably secured on the bottom of the boat.

When sailing with an outboard engine the steersman should shift his body forward in the course of acceleration to prevent the boat forebody from raising under the force of upthrust waves.



Despite the strong shell of the boat we recommend carefully handle and operate with sharp and pricking objects which you have on board . It concerns, for example, a knife blade, fish-hook point, etc.



Approaching to rocky shores, shoals, moles, etc. , please be careful to avoid damages of your boat. It is strictly prohibited to drag the boat across rough surfaces (shingle, rocks, concrete, etc.).

In case of prolonged navigation with the use of an outboard motor, regularly check, that the motor is reliably attached to the boat. If the engine was attached carelessly, the attachment may loosen under the action of vibration.



Besides, at regular intervals, please check air chambers pressure , since the pressure may vary under the effects of outside air temperature and atmospheric pressure variations.

Never forget to monitor regularly the quantity of fuel in the fuel tank. Keep always in mind that the quantity of fuel should be sufficient for you to sail to your final destination.

● Towing



At towing the towing rope length should not be less at least 3 lengths of the boat.

The steersman of the towed boat should be assisted by another crew member to monitor the process of towing. In this case, certain communication gestures should be agreed upon beforehand.



The rope have to be attached to both boats in a manner ensuring its immediately, single-motion release.

- **Damage to one of air chambers**

The inflatable boat is designed to provide an adequate stability in case of the complete damage to one of the air chambers (balloon compartments) at the expense of the remaining air chambers and the hull. Thanks to it, you will be able to reach safely the nearest shore. Reduce the speed and shift your body to the undamaged part of the boat. Observe changes in stability. After that, immediately head for the nearest shore. To prevent penetration of water into the boat, pull the shell of the damaged air chambers upwards.

- **Mooring fast fastening**



Attach towing rope in the bow of the boat to the one of the frontal towing rings. Attach bow mooring ropes to the bow mooring cleats only. Attach rear mooring ropes or the rope of back anchor to the rear mooring cleats only.

- **Danger of currents and wind**



Before begin navigation on the boat, make detail inquiries about local conditions and regulations! Currents, wind, shoals, rising and falling tides, as well as weather variations may imply serious danger!

- **In emergency stay in boat**

In any unexpected situation (engine failure, boat damage, etc.), never leave the boat, if it is still afloat. Even if you believe that the shore is just nearby, stay in the boat, since you will be looked for in this particular place and, most probably, will be found. Should the boat become partially flooded, throw heavy objects (batteries, fuel tank, engine) overboard to ensure additional floatability.

- **Handling under power**



Manoeuvrability above **50 knots (92 km/h)** is limited. Sudden turn may cause loss of control. Reduce speed before sharp turn, in either direction.



ATTENTION

Maximum propulsion power rating for the boat
2x261 kW (2x350 HP) or 298kW (400HP)



WARNING

Do not operate your boat with an engine of rated power larger than that stated on the builder's plate in the boat.



ATTENTION

Do not operate this craft at negative propulsion unit trim settings (bow down) at high speed. Craft may lean over on side. Instability in turns may result. Use negative trim to accelerate to planing speed from displacement speed and at lower planing speeds in choppy water (applicable to craft equipped with propulsion unit power trim).



ATTENTION

Do not operate at maximum speed while in congested high traffic waterways or in weather and sea conditions of reduced visibility high winds or large waves. Reduce speed and wake as a courtesy and as a safety consideration to yourself and others. Observe and obey speed limit and no wake zones



ATTENTION

Observe right-of-way as defined by Rules of the Road and required by COLREG.

Always be certain to have sufficient distance to stop or manoeuvre if required to avoid collisions.

The inflatable boat was delivered with the following equipment installed:

1.Fuel tank with fuel hoses	Stamp and signature	Comments:
-----------------------------	---------------------	-----------

2.Electric system	Stamp and signature	Comments:
-------------------	---------------------	-----------

3.Drain system.	Stamp and signature	Comments:
-----------------	---------------------	-----------

4.Bilge pump(s)	Stamp and signature	Comments:
-----------------	---------------------	-----------

5.Shower kit	Stamp and signature	Comments:
--------------	---------------------	-----------

6.Waste-water system	Stamp and signature	Comments:
----------------------	---------------------	-----------

7.Electrical anchor system	Stamp and signature	Comments:
8.Steering system	Stamp and signature	Comments:
9.Engine power system	Stamp and signature	Comments:
10.Engine installation, test and completion of plantsand fittings done by.	Stamp and signature	Comments:
		Comments:



MODEL

Eagle 10

SERIAL No.

UA-QRK

Date of manufacture

Quality inspection stamp