

OWNER'S MANUAL

English

SERIES: "NAVIGATOR"

MODELS: N520 N570 N610

complete set: N520 N570 N610
N520H* N570H* N610H*

2384C.01

Design category (2013/53/EU): C

H* – boat tube is made of HYPALON (Du Pont registered trademark) coated fabrics.

CONTENTS:

DANGER LEVELS	5
INTRODUCTION	5
IDENTIFICATION PLATE	6
SAFETY REGULATIONS	7
BEAUFORT Wind Scale and Corresponding State of the Sea, After Few Hours of Wind, Away From the Coast.	8
Boat Design Categories	9
REMEMBER FIRE DANGER ALWAYS	9
TECHNICAL SPECIFICATIONS	10
COMPLETE SET	11
THE MAIN DIMENSIONS	13
BOAT DESIGN	14
POLYESTER HULL	16
REINFORCED BUOYANCY TUBE	17
S.S. ARC	18
POLYESTER STEERING CONSOLE	18
FUEL SYSTEM	20
DRAIN SYSTEM	21
Care & Maintenance of your Sunbrella® Fabric	23
WIRING DIAGRAM	24
PREPARATION FOR EXPLOITATION	25
INFLATION/DEFLATION BOAT TUBE	25
STORAGE BATTERY INSTALLATION	26
BOAT TRANSPORTATION BY TRAILER	26
HOW TO INSTALL SUNDECK	28
MAINTENANCE	29
OPERATING REGULATIONS	30
WARNING SIGNS AND LABELS	41



For your safety and for the validity of the guarantee expert and authorised personnel must install the motor and inspect and check the systems. All onboard systems must be completed and inspected.

CHECK, THAT THE CHECKS HAVE BEEN MADE AND THAT THE PLANTS HAVE BEEN COMPLETED BEFORE DELIVERY.

BRIG Ltd declines any responsibility for systems and accessories that have not been installed and checked by expert and authorised personnel.



The manual and all its enclosures should be stored carefully, and the manual should always be kept aboard. If the craft is resold, the manual and all its enclosures must be handed over to the new owner.

CE Certification and Main Features

The CE marking indicates that the inflatable boat meets the requirements of the Recreational Craft Directive 2013/53/EU

Certifying Body:

INTERNATIONAL MARINE CERTIFICATION INSTITUTE

Rue Abbe Cuypers 3 / B-1040 Bruxelles / Belgique

Notified Body : 0609

www.imci.org

Name of Manufacture:

BRIG Ltd.

Lozovskaya 88, Dergachy 62303

Kharkovskaya obl.

UKRAINE

www.brig-ribs.com

DANGER LEVELS.

The manual contains warnings, identified as follows:



A note like this indicates that there is serious risk, that is likely to cause death or permanent serious injury, if appropriate precautions are not taken.



A note like this indicates the existence of risk that may cause death or injury, if appropriate precautions are not taken.



A note like this indicates reference to the application of safety or environmental protection practices, or draws attention to unsafe behaviour that might cause injury to persons or damage to the craft, its components or the environment.

INTRODUCTION.

This manual was written to help you to use your boat safely. It contains information on the boat, its equipment (supplied or installed), operation and maintenance.



Before using your boat, read this MANUAL carefully and ensure that you have understood all the procedures it describes. Before taking command of your boat, be sure to have acquired experience and confidence in its operation.

IDENTIFICATION PLATE.

Builder's Plate:

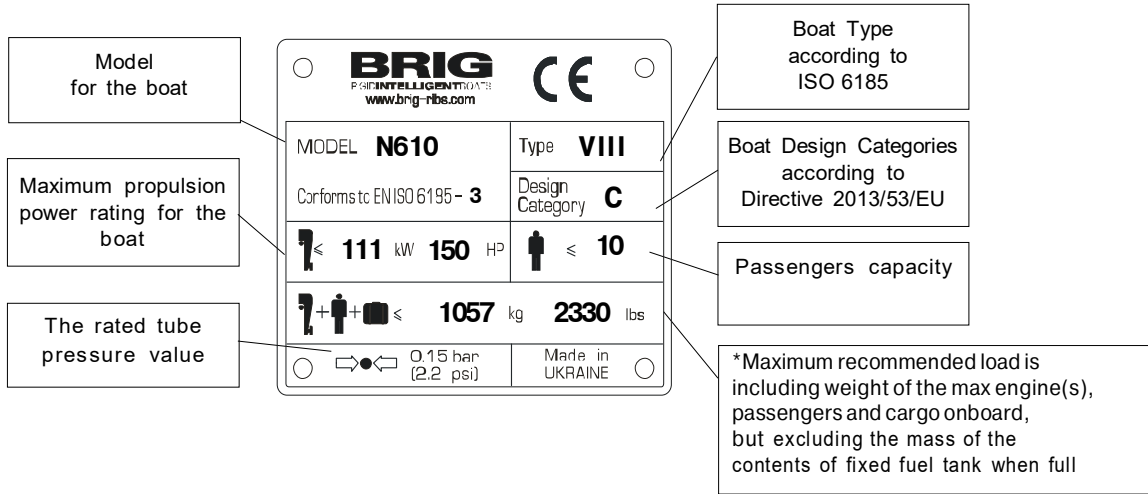
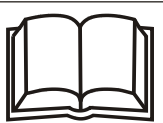

Plate with identification number:

UA-QRK12345A000





ATTENTION

It is fundamental for the plates to be aboard the boat, since they are only form of recognition and identification. Without them the boat does not comply with the legislation in effect. The plates must never be removed. Any tampering or removal not authorised by the manufacturer is the full responsibility of the owner.

SAFETY REGULATIONS.

This manual contains recommendations and basic rules of conduct for using the boat in complete safety. Although it is not possible to offer safety information for all potential situations, in general it is recommended that you :

	Regularly check which safety requirements are in force.
	Maintain the boat and the onboard plants in optimum condition.
	Have the boat inspected by the dealer where it was purchased or by an authorised mechanic at least once every year for your own safety and for maintaining the guarantee.

	Always check weather and seagoing conditions before setting out. For safe navigation, compare the design category of your boat with the table below.
	When the tank is installed by the yard, the plant is prepared with a ground plait. The installation of the motor MUST FORESEE A PLAIN CONNECTION to the boat ground plait. Failure to connect (or failed maintenance) can result in the tank perforating leading to a serious risk of fire / explosion caused by leaking fuel.

	Max number of transportable persones is referred to an established weight of 75 kg per person (ISO 6185), so always make reference to total maximum transportable weight. The max weight of the installable motors indicates the maximum overall weight applicable on the stern board, including any emergency motors. NEVER exceed the stated value.
---	---

BEAUFORT Wind Scale and Corresponding State of the Sea, After Few Hours of Wind, Away From the Coast.

Force	Denomination	Knots	Km/h	m/sec	State of the sea and wave height in meters	
0	Calm	<1	<1	0-0.2	Calm	0
1	Light Air	1-3	1-5	0.3-1.5	Calm	0
2	Light Breeze	4-6	6-11	1.6-3.3	Almost calm	0.2
3	Gentle Breeze	7-10	12-19	3.4-5.4	Almost calm	0.2
4	Moderate Breeze	11-16	20-28	5.5-7.9	Small waves	0.5
5	Strong Breeze	17-21	29-38	8.0-10.7	Large waves	1.25
6	Fresh Wind	22-27	39-49	10.8-13.8	Large waves	2.0
7	Strong Wind	28-33	50-61	13.9-17.1	Very large waves	2.5
8	Gale	34-40	62-74	17.2-20.7	Rough sea	4
9	Strong Gale	41-47	75-88	20.8-24.4	Very rough sea	6
10	Storm	48-55	89-102	24.5-28.4	Heavy	9
11	Violent Storm	56-63	103-117	28.5-32.6	Very heavy	14
12	Hurricane	64 and over	118 and over	32.7 and over	Stormy	14 and over

Boat Design Categories (Directive 2013/53/EU):

Design category	Wind force (Beaufort scale)	Significant wave height
"A" - "Ocean"	exceeding 8	exceeding 4
"B"- "Offshore"	up to, and including, 8	up to, and including, 4
"C"- "Inshore"	up to, and including, 6	up to, and including, 2
"D"- "Sheltered waters"	up to, and including, 4	up to, and including, 0.3

NOTE: **The significant wave height** is the mean height of the highest one-third of the waves, which approximately corresponds to the wave height estimated by an experienced observer. Some waves will be double this height.

ALWAYS REMEMBER ABOUT FIRE DANGER .

Fire may be caused by:

Crew negligence when smoking, the presence aboard of flammable liquids, electrical contacts, propulsion motor, errors in fueling, or if maintenance has not been performed as required.

Once again, it is important that the crew behave correctly and that the boat is kept in order to avoid serious damage to it and to persons.

 WARNING	Easily flammable products must not be kept aboard.
---	--

 DANGER	BATTERY: the battery may cause sparks or explosions. It must be stored in an appropriate container, easily reached and well aired, AWAY FROM FUEL OR INFLAMMABLE PRODUCTS. Periodically check that the clips are tight and protect them with appropriate insulation in order to prevent sparks or the spread of current.
--	--

However, if a fire does occur aboard, stop motor, disconnect the batteries immediately, check to see if it is an electrical component or any case a small-scale fire that does not involve flammable liquids, in which case use a suitable fire extinguisher to try and put the fire out completely.

 WARNING	Extinguisher or any other fire-fighting equipment must not be kept in compartments with key lock, but in easily accessible and clearly indicated locations.
	Extinguisher or any other fire-fighting equipment should be checked periodically and replaced with the same or superior types if expired or inefficient.

 DANGER	Equip the boat with fire-fighting equipment before launch and use.
--	--

TECHNICAL SPECIFICATIONS.

The basic parameters and dimensions of the "NAVIGATOR" boats comply with the data specified in the following table. All dimensions measurements indicated have a tolerance of +/- 3%, weight measurements indicated have a tolerance of +/- 5%.

Parameter	N520 (N520H)	N570 (N570H)	N610 (N610H)
Length (without engine)	5.2 m	5.7 m	6.1 m
Beam	2.3 m	2.3 m	2.3 m
Height	1.85m	1.85m	1.85m
Inflatable tube diameter, max.	0.5 m	0.5 m	0.5 m
Cockpit dimensions: - length	3.4 m	4.0 m	4.4 m
- width	1.3 m	1.3 m	1.3 m
Deadrise angle on transom	19°	19°	19°
Deadrise angle in middle section	22°	22°	22°
Transom height	500mm	500mm	500mm
Number of independent air-tight chambers	5	5	5
Nominal pressure	0.15 bar / 2.2 psi	0.15 bar / 2.2 psi	0.15 bar / 2.2 psi
Passengers capacity	8 (9**)	9 (10**)	10
Recommended engine power	75HP / 55kW	75HP / 55kW	90HP / 66kW
Maximum engine power	100HP / 74 kW	120HP / 89 kW	150HP / 111 kW
Maximum engine weight (including controls and battery)	230kg	280kg	282kg
Engine shaft length	20" (Long)	20" (Long)	20" (Long)
Built-in fuel tank capacity	98L	98L	121L
Weight of empty boat (without: steering console, arc, driver seat, fuel, engine)	340kg	380kg	420kg
Weight of boat with equipments (with steering console, with S.S.arc, with driver seat, without engine, without fuel)	440kg	480kg	570kg
Maximum load capacity of empty boat (ISO method)	1110kg	1220kg	1300kg
Displacement in Light Craft Condition (LCC)	675kg	765kg	860kg
Maximum total load (ML)	775kg	835kg	860kg
Maximum recommended load*	930*kg	1040*kg	1057*kg
Loaded displacement mass	1450kg	1600kg	1720kg

*Maximum recommended load is including weight of the max engine(s), passengers and cargo onboard, but excluding the mass of the contents of fixed fuel tank when full

**For American market only

COMPLETE SET .

In the table shows the maximum possible complete set, which may differ from your boat.

No	Description	Unit of measure	N520 / N570	N610
1	Inflatable boat	pcs.	1	1
2	Foot pump	pcs.	1	1
3	Paddle	pcs.	2	2
	<i>Set of spare parts and repair kit:</i>			
4	- mooring line	m	18	18
5	- coated fabric for repair	m ²	0.06	0.06
6	- glue set for repair	set	1	1
7	Bag	pcs.	1	1
8	Owner's manual	pcs.	1	1
9	Built-in fuel tank	pcs.	1 (98L)	1 (121L)
10	Steering console with installation kit	pcs.	1	1
	<i>Steering console equipment:</i>			
11	Mechanical steering system	pcs.	1	1
12	Mechanical steering system cable	pcs.	1	1
13	Hydraulic steering system	set	1 (variant)	1 (variant)
14	Steering wheel	pcs.	1	1
15	Fuel level clock	pcs.	1	1
16	Switches of electrical equipment	pcs.	4	4
17	Socket 12V with fuse	pcs.	1	1
18	Compass	pcs.	1	1
19	Speedometer	pcs.	1	1
20	Tachometer	pcs.	1	1
21	Electric horn	pcs.	1	1
22	Front locker removable cushion	pcs.	1	1
23	Jockey seat with installation kit	pcs.	2	4
24	Driver seat/bolster with installation kit	pcs.	1 (variant)	1 (variant)

No	Description	Unit of measure	N520 / N570	N610
25	Stainless steel arc with installation kit	pcs.	1	1
	<i>Arc equipment:</i>			
26	Anchor light (white)	pcs.	1	1
	<i>Running lights:</i>			
27	Port (red) Starboard (green)	set.	1	1
28	Drain automatic bilge pump	pcs.	1	1
29	Towing eye	pcs.	2	2
30	Soft back of stern-part seat	pcs.	1	1
	<i>Additional options:</i>			
31	Bow sun deck set with cushions	set	— / 1	1
32	Overall cover	set	1	1
33	Steering console cover	set	1	1
34	Driver seat (or Jockey seats) cover	set.	1	1
35	Collapsible sun-top	set	1	1
36	Battery container	pcs.	1	1
37	Valve cap pressure gauge	pcs.	1	1
38	Folding ladder	pcs.	1	1

Note. Perfection of the design and improvement of quality of our products is the fundamental production policy of our company. Therefore, alternations may be made to the complete set (and as the components become available).

THE MAIN DIMENSIONS.

The main dimensions of N520, N570, N610 have tolerance of +/- 3%.

The length of the boat with the engine(L1) can vary depending on the model of the engine and the angle of its deviation. (See Fig. D0)

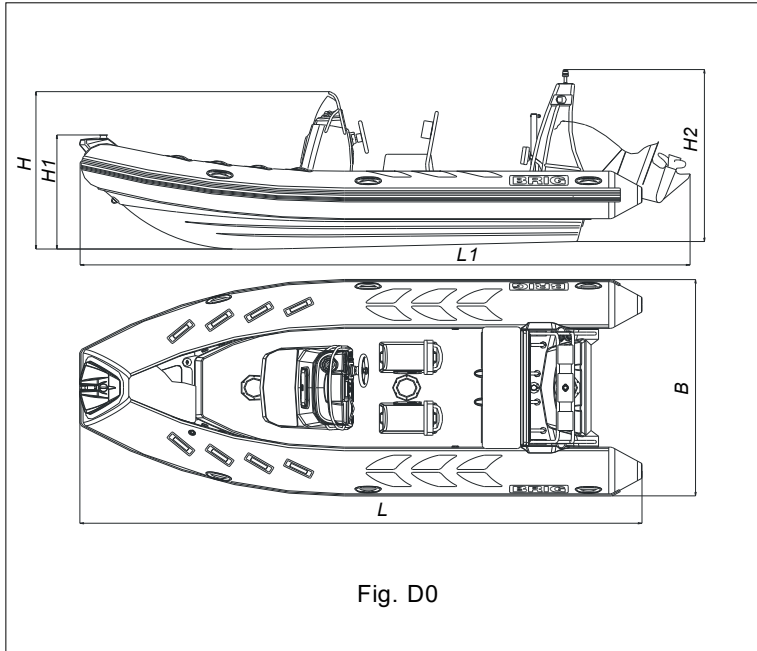

	N520	N570	N610
L	5.2 m	5.7 m	6.1 m
B	2.3 m	2.3 m	2.3 m
L1	5.6 m	6.1 m	6.5 m
H	1.7 m	1.85 m	1.85 m
H1	1.2 m	1.2 m	1.2 m
H2	1.85 m	1.85 m	1.85 m

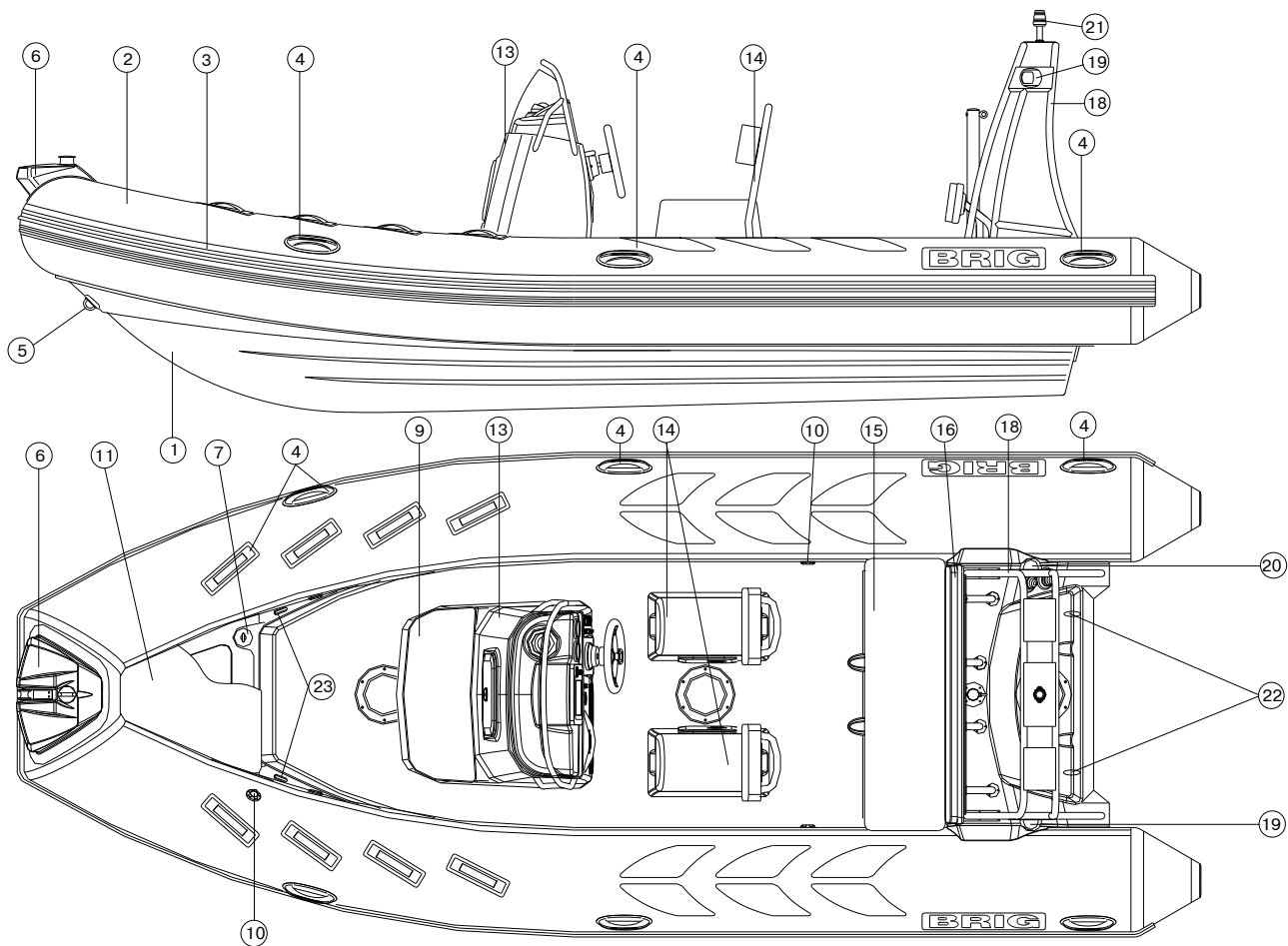

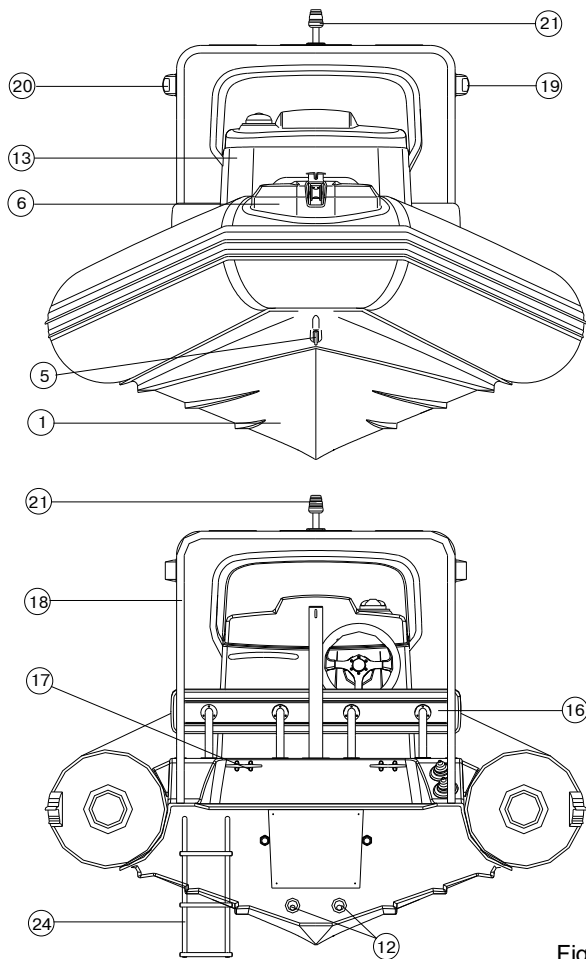

Fig.D1

BOAT DESIGN.

The boat series "NAVIGATOR" consists of the next main components (Fig. D1):

- polyester hull (1);
- reinforced buoyancy tube (2);
- polyester steering console (13);
- jockey seat or composed driver seat/bolster (14);
- stainless steel arc (18).

●DESCRIPTION:

- 1 — Polyester hull.
- 2 — Reinforced buoyancy tube.
- 3 — Doubled rubbing strake.
- 4 — Safety handle.
- 5 — Towing bow eye.
- 6 — Bow step-plate with bow roller.
- 7 — Neck for fuel fill.
- 9 — Steering console seat.
- 10 — Air fill valve (5 pcs.).
- 11 — Front locker removable cushion.
- 12 — Cockpit drain system socket (2 pcs.).
- 13 — Steering console.
- 14 — Jockey seats or Composed driver seat/bolster.
- 15 — Stern-part seat.
- 16 — Soft back of stern-part seat.
- 17 — Mooring cleats.
- 18 — Stainless steel arc.
- 19 — Port running light (red).
- 20 — Starboard running light (green).
- 21 — Anchor light (white).
- 22 — Stern lifting eye.
- 23 — Bow lifting eye.
- 24 — Folding ladder.

●POLYESTER HULL.

The boat hull has "deep-V" shaped bottom with four longitudinal steps. The upper deck has a special moulded antiskid coating. There is two specified sections (Fig. D2):

- bow locker (1) is intended for arrangement of anchor and anchor rope or for baggage arrangement;
- stern compartment (2).

The bow locker have a direct access by hinge out the access door (18). Onto the access door of the bow locker there is a removable soft cushion (11, Fig. D1). Onto the stern compartment door there is soft seat (15, Fig. D1) and soft back (16, Fig. D1).

The boat hull is arranged with the following components:

- bow towing eye (5, Fig.D2a);
- fuel tank (3);
- battery disconnect (6, Fig. D2b);
- cockpit drain system sockets (7, Fig. D2b, D2d);
- two stern lifting eyes (9, Fig. D2c);
- drain out of motor recess (10, Fig. D2c);
- drain automatic bilge pump (11, Fig. D2d);
- two bow lifting eyes (14);
- outer neck for fuel fill (13);
- inspection hatches (12);
- two stern cleats (17);

The fore part of the cockpit may be simply converted into the sundeck by means of false decks and soft cushions.

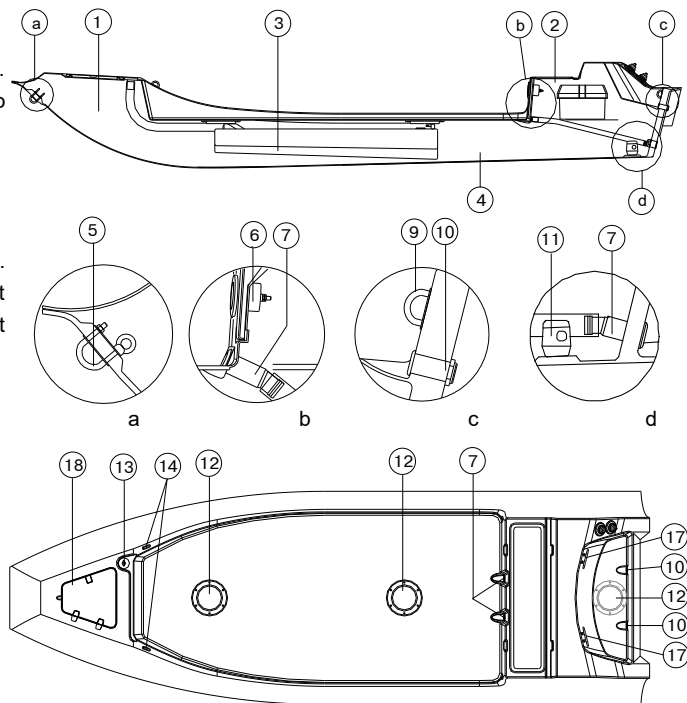

D2

●REINFORCED BUOYANCY TUBE.

The boat buoyancy tube has U-shaped form. The tube is separated by means of inner elastic partitions into five chambers of a similar volume, each being provided with an air fill valve.

The air fill valve is intended for:

- filling the compartment with air from a standard pump or filling system and maintaining pressure in the tube for prolonged time,
- adjustable drop of pressure in compartment.

The air fill valve is designed as a tab-type non-return valve and consists of the following components (Fig. D3):

- housing (1);
- cup (2) with strap (3);
- washer with gasket (4);
- nut (5);
- spindle (6) with spring (7) and cup diaphragm (8).

Also there are the following elements fitted on the tube (Fig. D1):

- doubled rubbing strake (3, Fig.D1);
- safety handles (4, Fig.D1);
- bow step-plate with a special moulded antiskid coating (6, Fig.D1).

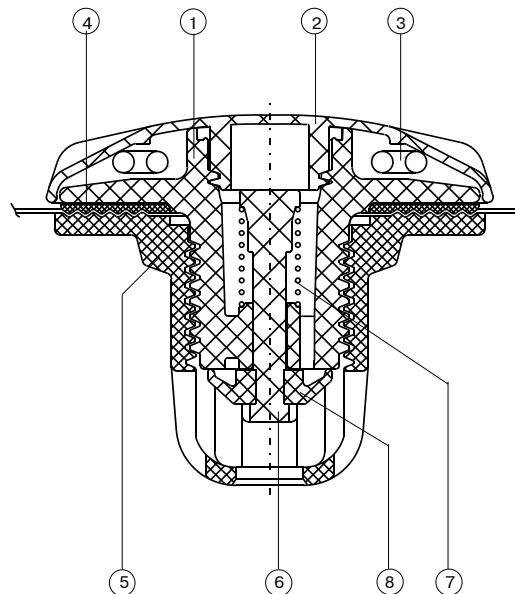

D3

●STAINLESS STEEL ARC.

Stainless steel arc (18, Fig.D1) is located in the stern part of the boat. Arc is equipped with anchor light (white, 21) and running lights: port (red, 19) and starboard (green, 20), (Fig. D1).

●POLYESTER STEERING CONSOLE.

Steering console is located in the central part of the boat. The console consists of the following components (Fig. D4):

- console base (1);
- console upper part (2);
- windscreen (3);
- stainless steel railing (4);
- front soft seat (5) (not applicable for N520)
- console recess (7);
- special place for installation of analog or/and digital devices, such as speedometer, tachometer, trim-meter, fuel-level meter, multipurpose meters, GPSmap, etc. (8);
- small hatch in the front of the upper part of the console with soft cushion;
- electric horn (on the right side of the upper part of the console).

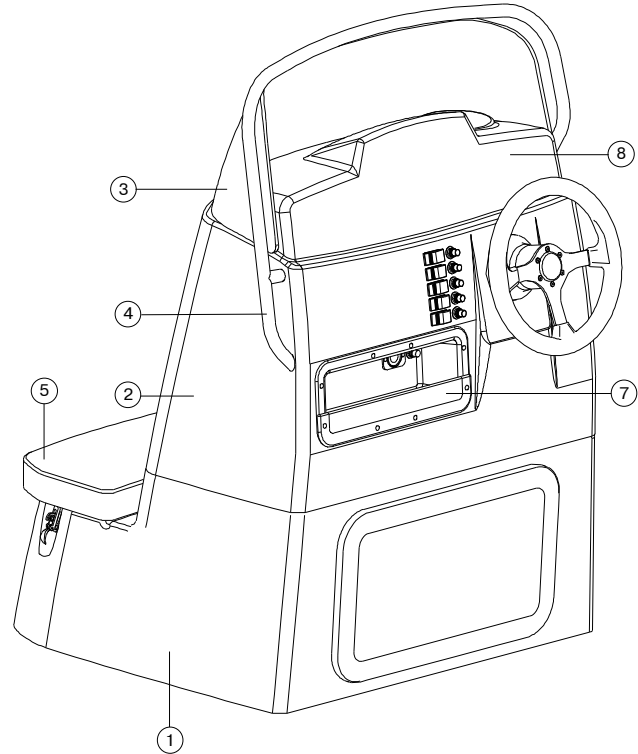

D4

Console equipment (Fig. D5):

- mechanical or hydraulic steering system;
- steering wheel (1);
- compass (2);
- fuel-level meter;
- speedometer;
- additional equipment (tachometer or multi-purpose meter, trimmer, voltmeter, clock);
- socket 12V with fuse (3);
- fuse holding box with warning lights (inside of the steering console)
- switches:
 - electric horn switch (4);
 - anchor light switch (5);
 - running lights and meter lamp switch (6);
 - bilge pump switch (7);

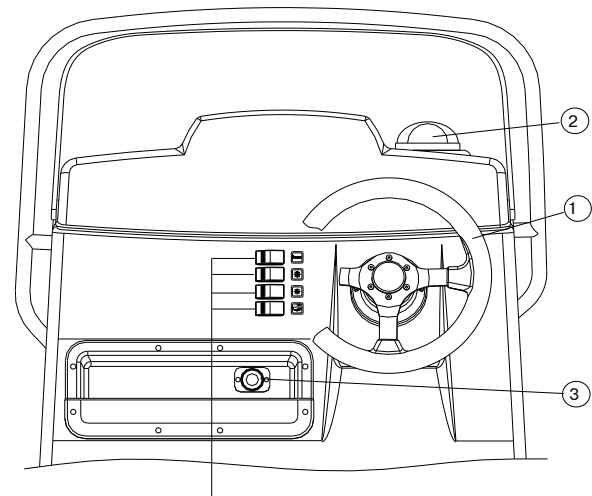



WARNING

Always check the fuse. Burning red LED display on the fuse box warns of faulty fuse



WARNING

Always keep a spare set the fuse in an easily-accessible location.

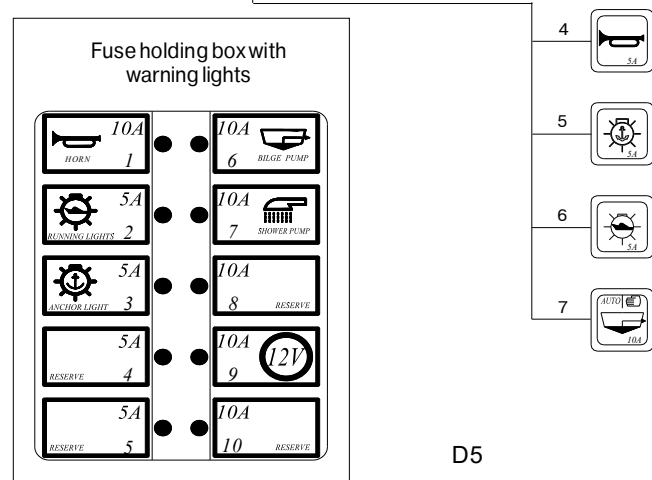

D5

●FUEL SYSTEM.

Fuel system consists of the following components (Fig. D6):

- built-in fuel tank (1);
- electric fuel gauge (2);
- outer neck for fuel fill (3);
- fuel hose (from outer neck for fuel fill to fuel tank) (4);
- fuel hose (from fuel tank to outboard motor) (5);
- fuel venting hose (6).

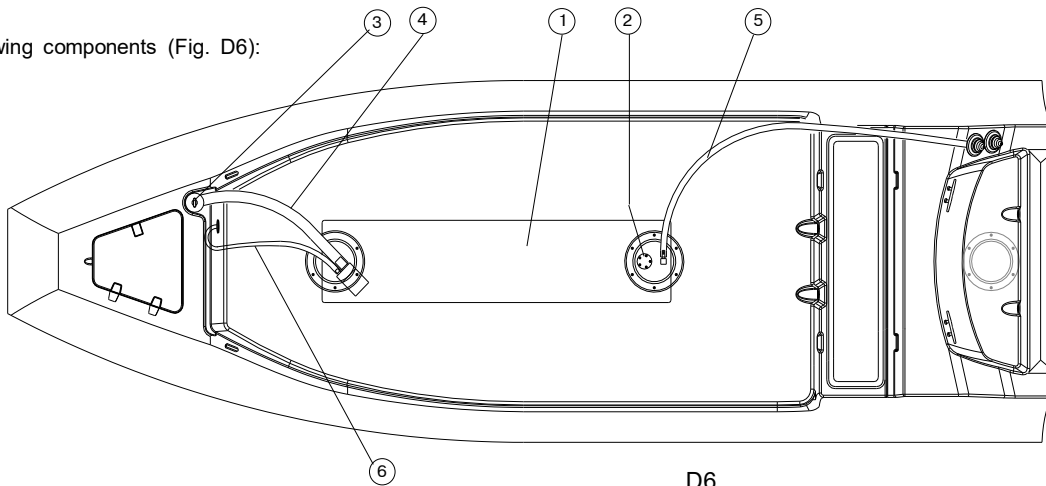

D6



Pre-filter and fuel valve must be installed by authorized representative specialists only.

Do not modify fuel system. Any modification, repair and planned maintenance of the fuel system may be made by authorized representative specialists only.

Check that there are no leaks in the fuel systems



Do not smoke when refueling. Stop the engine and switch off any electric equipments before refueling.

It is dangerous to pretend to be an expert. This may cause damages. Refer to expert and authorized specialists for all types of maintenance and repair.

●DRAIN SYSTEM.

Drain system, (Fig. D7, D8), consists from two independent systems:

- cockpit and motor recess drain system;
- hull drain system.

COCKPIT AND MOTOR RECESS DRAIN SYSTEM includes:

- two cockpit drain sockets (1);
- two stern drain sockets with flexible diaphragms (2);
- two drain hoses (3);
- drain socket thru-hull out of motor recess (4);

HULL DRAIN SYSTEM includes:

- automatic bilge pump (5);
- drain hose (6);
- drain socket installed in the motor recess (7);
- bilge drain socket (8) (Fig.D8).

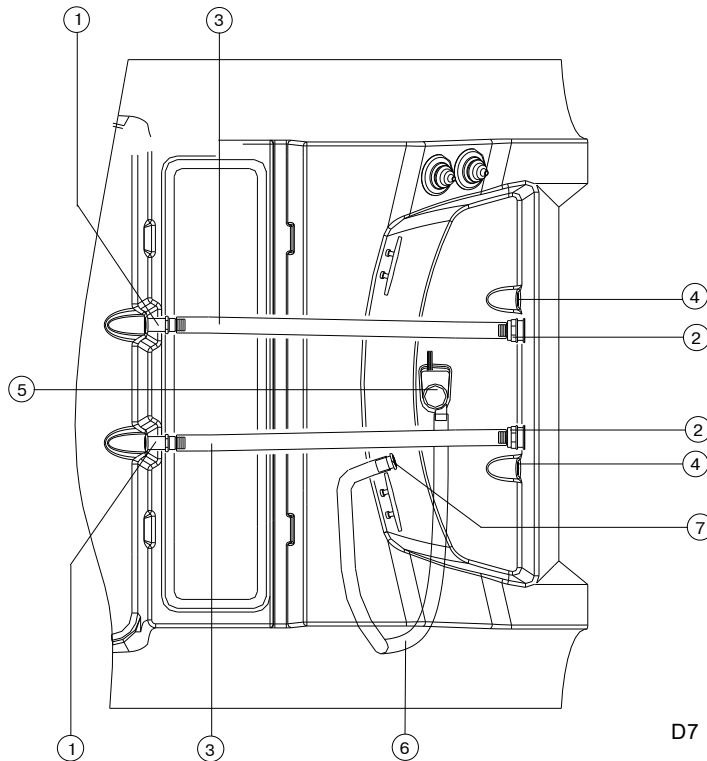



Always the cockpit drain sockets must be open during navigation. Do not obstruct cockpit drain sockets at any time. Do not dispose bulky objects in front of the cockpit drain sockets.

Do not modify drain systems. Before navigation check the drain valves.

Never locate heavy objects on the drain hoses. It will be cause of bucking, distortions and damages.

 <p>WARNING</p>	<p>Bilge valve (8)(Fig.D8) should be tightly CLOSED when the boat on the water</p> <p>Bilge valve (8)(Fig.D8) should be open when the boat is out of the water</p>
---	--

 <p>WARNING</p>	<p>It is dangerous to pretend to be an expert. This may cause damages. Refer to expert and authorized specialists for all types of maintenance and repair.</p>
---	--

 <p>WARNING</p>	<p>Always the cockpit drain sockets must be open during navigation. Do not obstruct cockpit drain sockets at any time. Do not dispose bulky objects in front of the cockpit drain sockets.</p>
---	--

 <p>WARNING</p>	<p>Do not modify drain systems. Before navigation check the drain valves.</p>
---	---

 <p>WARNING</p>	<p>Never locate heavy objects on the drain hoses. It will be cause of bucking, distortions and damages.</p>
---	---

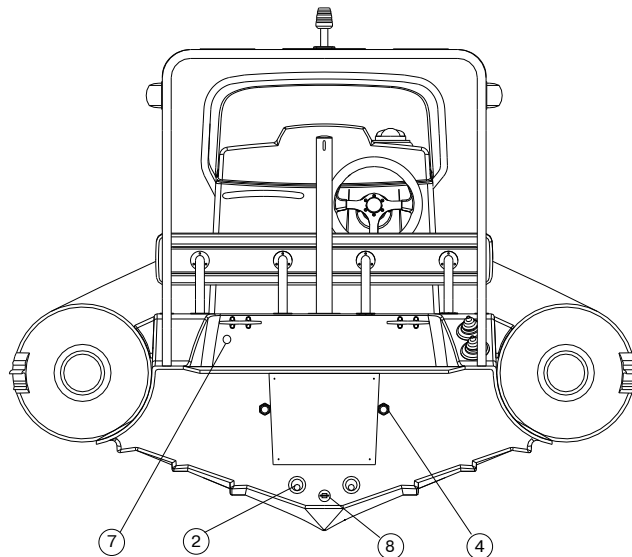

D8

●CREW LIMIT.

The number of passengers in the boat is limited. The maximum possible number of passengers is indicated in the technical data and on the builder's plate. Never exceed the crew limit.

Always check that the passengers in the boat are sitting in the designated seating area.

Passengers should always use the handholds to avoid falling overboard.

Any part of the boat can be a handholds that can be grabbed by hand to reduce the risk of falling overboard.

Example: handle, shroud, seat edge, cleats, steering wheel.

On the picture (Fig.D8A) you can see the recommended location of the crew in the boat N520 (N520 with jockey seats).

In order to use the bow seat (persons indicated in the figure as A and B) SunDeck must be folded while the boat is in moving.

Persons indicated in the figure as B and F can be placed on the tube of the boat.

However, they should always use two handholds for holding with both hands. When placing persons on the tube, you must be careful while the boat is moving to prevent people from falling and injuring themselves.

We do not recommend placing persons on the tube during a great sea swell and strong wind.

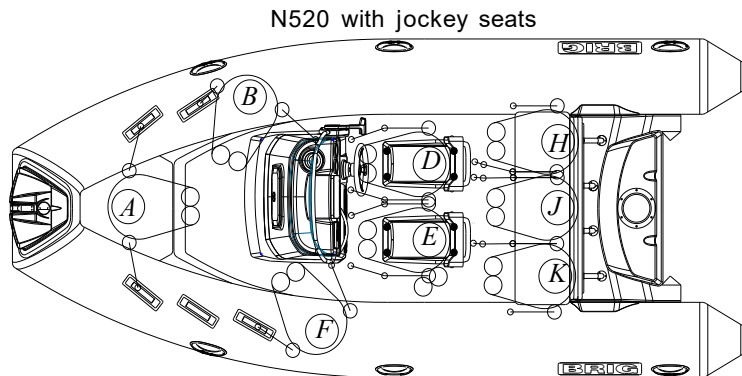
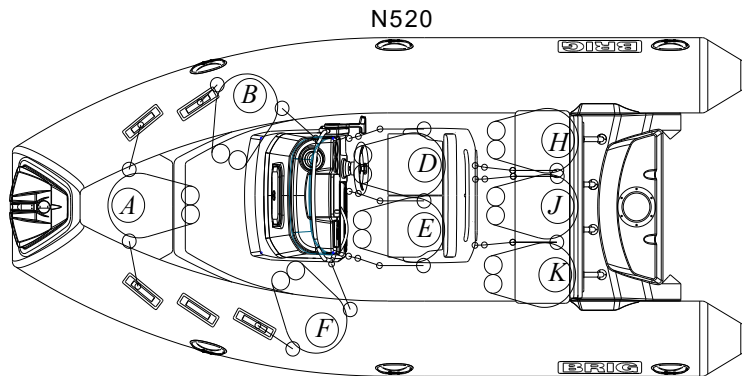
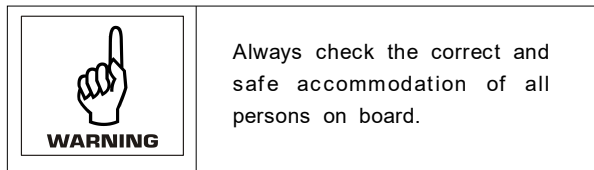

D8A

On the picture (Fig.D8B) you can see the recommended location of the crew in the boat N570 (N570 with jockey seats).

In order to use the bow seat (persons indicated in the figure as A, B and C) SunDeck must be folded while the boat is in moving.

Person indicated in the figure as F can be placed on the tube of the boat.

However, they should always use two handholds for holding with both hands. When placing persons on the tube, you must be careful while the boat is moving to prevent people from falling and injuring themselves.

We do not recommend placing persons on the tube during a great swell and strong wind.

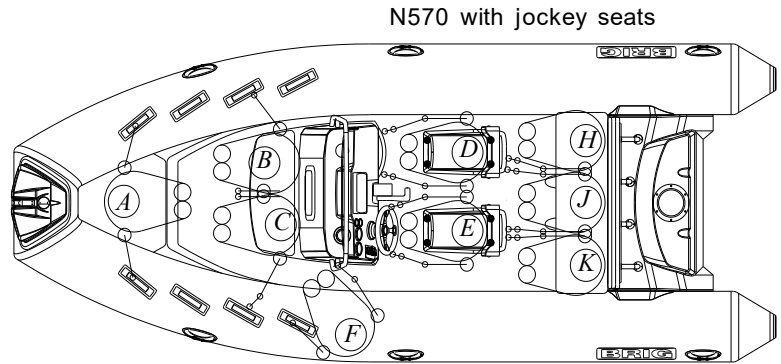
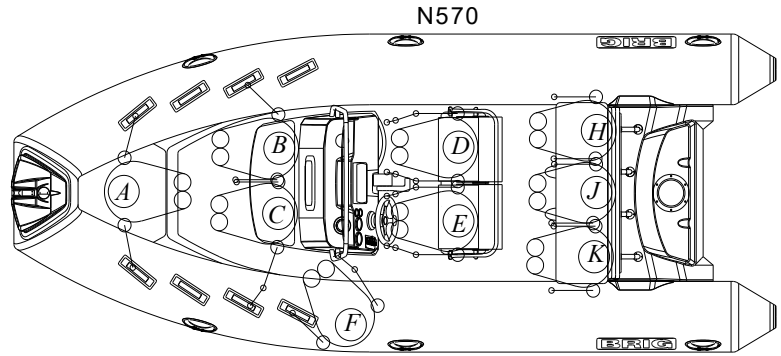

 WARNING	Always check the correct and safe accommodation of all persons on board.
---	--

 WARNING	Periodically check the handholds. There should be no damage on the handholds and their fixation.
---	--

D8B

On the picture (Fig.D8C) you can see the recommended location of the crew in the boat N610 (N610 with jockey seats).

In order to use the bow seat (persons indicated in the figure as A, B and C) SunDeck must be folded while the boat is in moving.

Persons indicated in the figure as F and G (N610) can be placed on the tube of the boat.

However, they should always use two handholds for holding with both hands. When placing persons on the tube, you must be careful while the boat is moving to prevent people from falling and injuring themselves.

We do not recommend placing persons on the tube during a great sea swell and strong wind.

N610

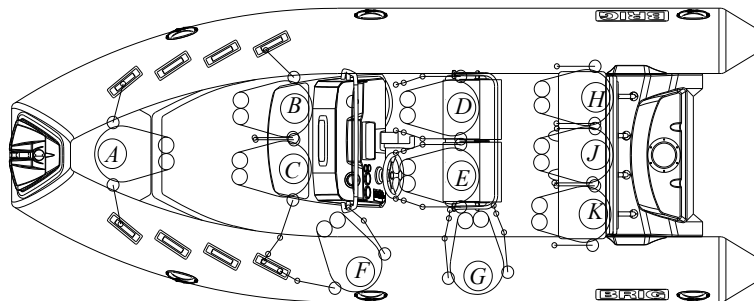

N610 with jockey seats

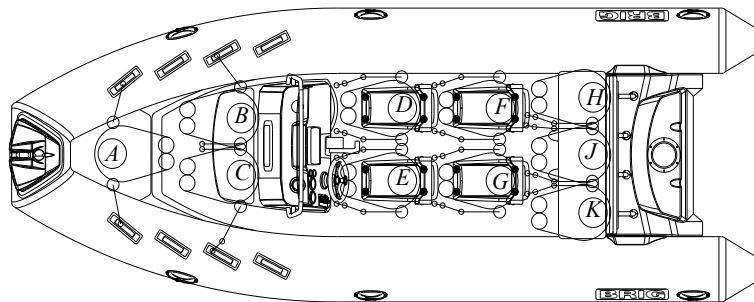

D8C

 WARNING	Always check the correct and safe accommodation of all persons on board.
---	--

 WARNING	Periodically check the handholds There should be no damage on the handholds and their fixation.
---	--

●REBOARDING MEANS.

Foldable ladder is installed on the stern of the boat on the left side(Fig.D8D).

If you are in the water and the ladder is folded, you can lay it out and get back on board.

The ladder can be secured with velcro. Just unplug it.

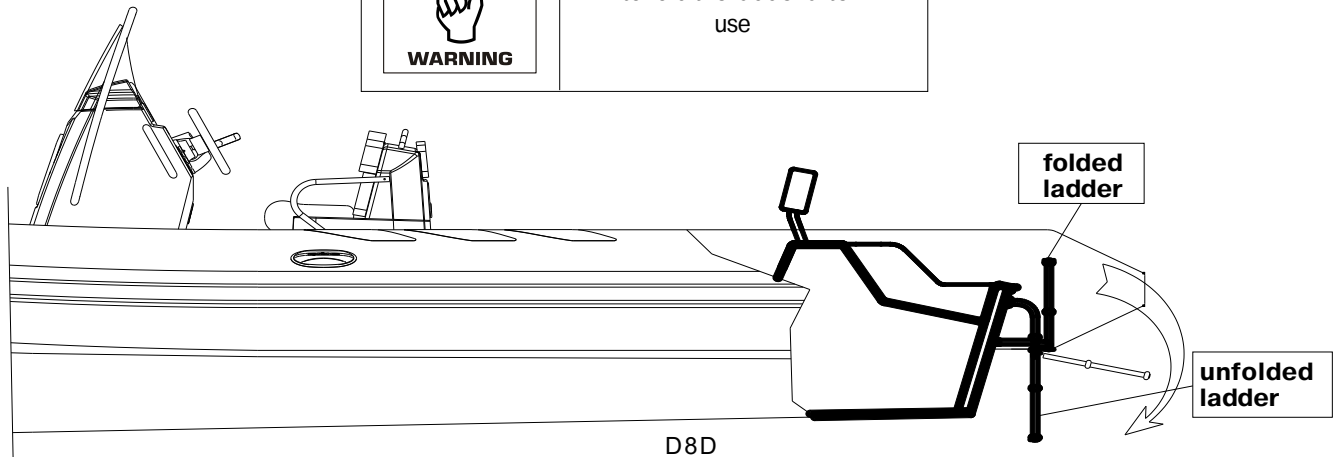
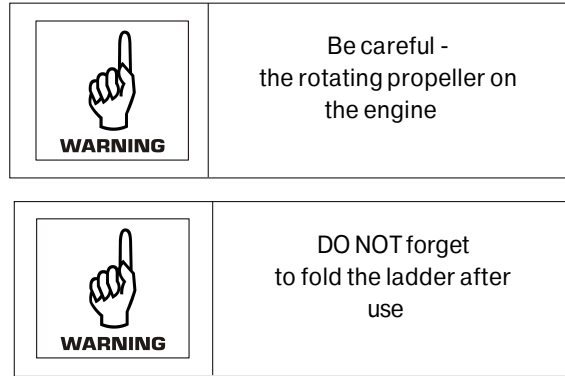

●ANCHORING AND TOWING. Strong points.

On the boat there is space to accommodate the anchor (Fig.D8F).

- 1 - anchor storage compartment
- 2 - inner ring for fixing rope
- 3 - U-bolt for fixing the anchor / tow rope
- 4 - bow plate
- 5 - bow roller
- 6 - clam-bollard for rope 6-10mm

Equip your boat with an anchor of suitable size and type.

Fix the rope for anchoring / towing only for U-bolt (3).

Rope for anchoring / towing must be appropriate strength, diameter and length.

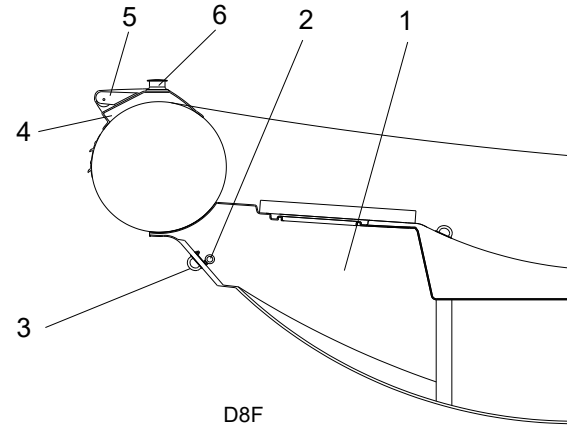

U-bolt (3) is designed for a maximum load of 16kN.
The breaking strength of rope shall in general not exceed 80 % of the breaking strength of the respective strong point.



A tow line shall always be made fast in such a way that it can be released when under load.

Always tow or be towed at a slow speed. Never exceed the hull speed of a displacement craft when being towed.



Always use a roller (5) and clam-bollard (6) to tighten the rope to avoid damage of the buoyancy tube.

Roller and clam-bollard are made of nylon and have a limited lifespan. Check them periodically for damage. Replace them if necessary.

●MOORING. Strong points.

For mooring on the boat models N520, N570, N610 installed two stern cleats (Fig.D8G).

Use only these cleats for mooring.

Do not use other parts and elements of the boat for mooring.

Make sure that the mooring rope does not damage the buoyancy tube or other elements of the boat.

Rope for mooring must be appropriate strength, diameter and length.

For bow mooring you can use clam-bollard, but only in calm water for a short time.

If you are leaving the boat and there is a possibility of rough water or strong wind, use only bow U-bolts (3) Fig.D8F to bow mooring.

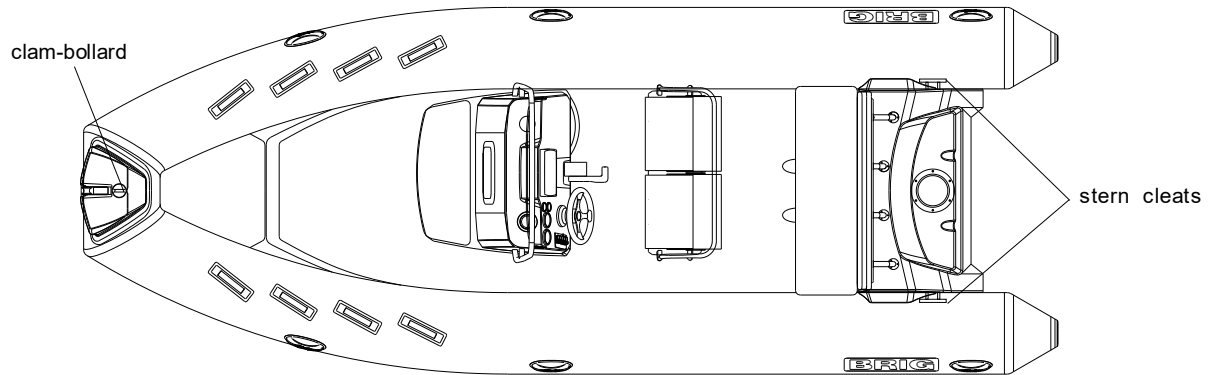

D8G



Cleats are designed for a maximum load of 14kN.
The breaking strength of rope shall in general not exceed 80%
of the breaking strength of the respective strong point.



Be careful when mooring. Suddenly tensioned mooring
ropes may cause injury.



Always have mooring ropes on board in an easily
accessible place.

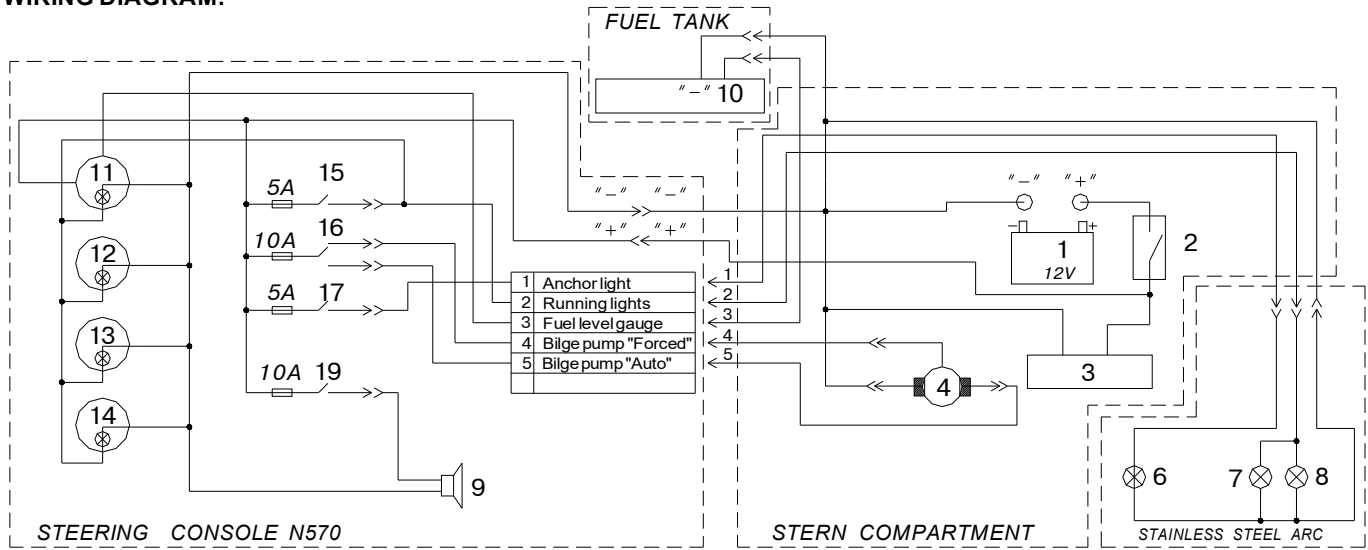

● **WIRING DIAGRAM.**



D9

DESCRIPTION:

- | | |
|---|--|
| 1 — Battery (is not included to the complete set). | 12 — Tachometer. |
| 2 — Battery disconnecter. | 13 — Compass. |
| 3 — Outboard motor (is not included to the complete set). | 14 — Speedometer. |
| 4 — Bilge pump. | 15 — Switch with automatic circuit breaker — meter lamp and running lights switch. |
| 6 — Anchor light (white). | 16 — Switch with automatic circuit breaker — bilge pump "FORCED" / "AUTO" |
| 7 — Port light (red). | 17 — Switch with automatic circuit breaker — anchor light (white). |
| 8 — Starboard light (green). | 19 — Switch with automatic circuit breaker — electric horn. |
| 9 — Electric horn. | |
| 10 — Fuel level gauge. | |
| 11 — Fuel level meter | |

 WARNING	<p>Do not modify electrics of the boat. Any modification, repair and planned maintenance may be made by authorized representative specialists only.</p>	 ATTENTION	<p>When leaving the boat, remember to disconnect the batteries.</p>
	<p>Do not touch the electrical equipment with wet hands.</p>		

PREPARATION FOR EXPLOITATION.

In order to set the boat in the operation condition perform as follows:

- unfold the inflatable tube;
- mount the outboard motor on the transom in accordance with its own installation instruction (manual of your outboard engine).

●INFLATION/DEFLATION OF THE BOAT TUBE.

The inflatable tube of the boat has five independent air-tight chambers. Before inflation it's necessary to set all valves in operating condition. In order to switch valve in operating condition, please press spindle 6 (Fig. D3) with your finger and rotate it clockwise until the spindle will be fixed. If this operation isn't possible, it means the valve already has been set in operating condition.

Fill the tube with air using the pump from the complete set. First fill two rear chambers, next two middle chambers. However, do not increase the pressure up to its operating value (the tube will be completely straightened). After that, please fill the fore chamber up to the rated pressure. **The rated pressure value is 0.15 bar (2.2 psi).** Having completed filling, close the valve covers.

In order to discharge air from the tube chambers, open the valves (please press spindle 6 (Fig. D3) with your finger and rotate it anticlockwise until the spindle will be fixed).

 WARNING	<p>Do not use compressors and/or other types of inflating equipments not approved by the boat builder.</p>
	<p>Check the tube pressure before every navigation.</p>
	<p>The rated pressure value is 0.15 bar (2.2 psi). If the tube pressure more than nominal, deflate the tube slightly. Boat exploitation with board pressure more than nominal decreases boat service life.</p>

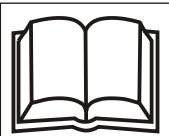

ATTENTION

Board air chambers are hermetical if they keep own form during 8 hours. In this case:

- primary pressure has to be nominal;
- input valves openings have to be tightly closed by caps.

●STORAGE BATTERY INSTALLATION.

In order to install the storage battery, perform next operations:

- open door of the stern compartment;
- install the storage battery into the battery container;
- connect the battery terminals with motor battery cord and battery disconnecter;
- please, check efficiency of the electric equipment.



WARNING

Before installation your storage battery read the BATTERY MANUAL carefully and ensure that you have understood all the described procedures.

BOAT TRANSPORTATION BY TRAILER.

Installed on a trailer (or on kell-blocks for storage) the boat should be laying on all surface of the Main loading area (keel line) (see Fig. D10).

It is possible to install the boat on several reference points. Thereby the point of support (1) must be an obligatory, and the point of support (2), (3), (4) must be an additional.

Lateral roller supports can be used only with a view of prevention from tipping.

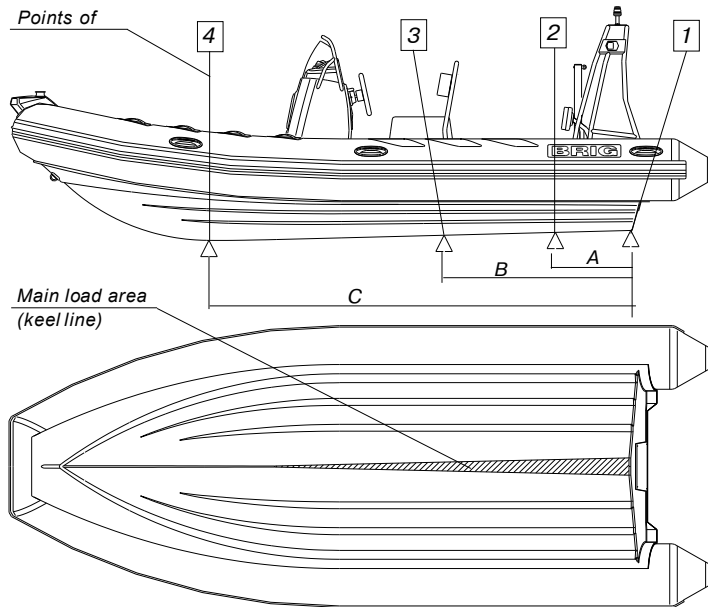

D10

	N520	N570	N610
A	640mm	640mm	640mm
B	1500mm	1500mm	1500mm
C	3000mm	3300mm	3700mm

All sizes have tolerance of +/- 50 mm

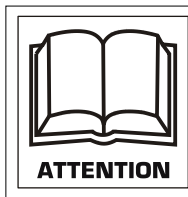

Maximum transportable mass
N520 – 775 kg
N570 – 850 kg
N610 – 970 kg

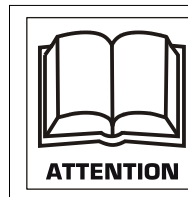

In order to avoid the hull damage, install the boat on the stated areas only.

● **HOW TO INSTALL SUNDECK (not applicable for N520).**

Sundeck set includes two false deck boards and two soft cushions. One of the boards (the small one) may be used as an upper part of the demountable table. In order to install the sundeck (Fig. A1), please do the next:

- Open front seat of the steering console (Fig. A1a).
- Put false deck boards into the special drops in the front wall of the cockpit and the front wall of the console, (Fig. A1b).
- Close the front seat of the steering console (Fig. A1c).
- Further, please place two soft cushions onto the false decks and fasten them with the help of press-buttons (Fig. A1d).

front seat of the steering console

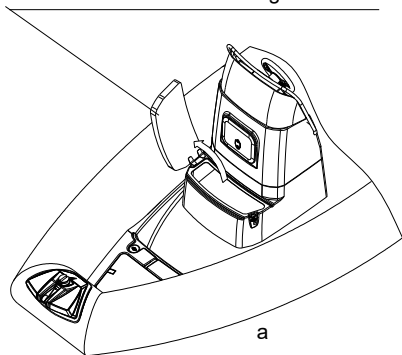

false deck boards

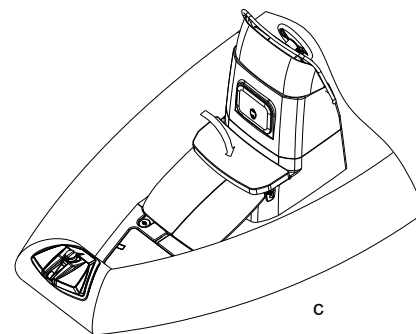
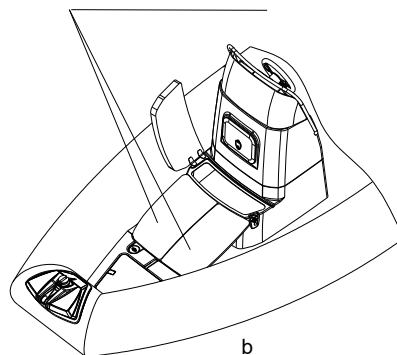

Two soft cushions

Front locker removable cushion

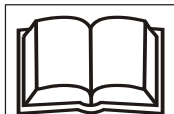
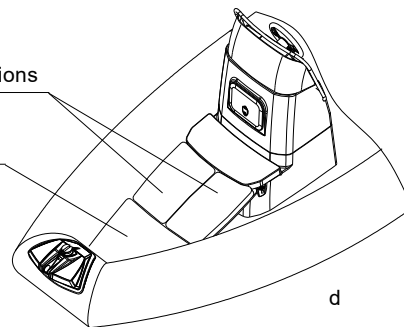

ATTENTION

Always check fixation of the sundeck cushions.

A1

"BRIG" inflatable boats

MAINTENANCE.

- Main conditions of long service life is right and careful servicing. Avoid excessive increasing of pressure in the board, especially from heating by the sun rays.
 - At the end of exploitation take off sand and dirt from boat surface, and carefully dry it.
 - Avoid the water getting into the chambers. If a fuel or an oil gets to the boat surface it is necessary to wash the soiled place by soap water as soon as possible and dry.
 - Pay attention to the condition of bottom surfaces. If the cover is destroyed it is necessary to dry this element and restore the defend cover.
 - At the end of the season exploitation, prepare the boat to winter keeping. Clean boat surface from sand and dirt, and make the necessary repairs, if damages take place. If it is possible, keep the boat in open and slightly pumped state at air temperature 0-25°C. The boat must be protected from the sun rays.
 - Insignificant boat repairing (eliminating the board punctures or cuts) you may carry out by yourself. In this case use the coated fabric and glue set for repair from the complete set.
- The own fulfilment of any complex repair associated with considerable damages to the board, partitions and seams is not recommended. In such cases, apply to your dealer.

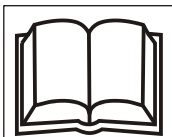

ATTENTION





Storage of the boat with temperature variations from -30°C to +45°C may be allowed not longer than 1 month. In case the boat has been stored or transported at a temperature below 0°C, it must be kept at a temperature above +15°C at least for 1 hour before to be unpacked and unfolded.

For small repair boat tube use the coated fabric and glue set from the complete set.

OPERATING REGULATIONS.

Dear user,

We thank you for your purchase and do hope that you will have a great fun of it. However, to make your joy and pleasure complete, we would request you to read carefully and observe the directions and recommendations specified below.

 <p>DANGER</p>	IT IS STRICTLY FORBIDDEN to handle the boat in the state of intoxication and without individual rescue means being used (life-saving belts, jackets, etc.)
	IT IS FORBIDDEN to use an outboard motor of power exceeding the maximum allowable value
 <p>WARNING</p>	IT IS FORBIDDEN to bring the tube pressure up to the value exceeding the rated one (0.15 bar(2.2psi))
	IT IS STRICTLY FORBIDDEN to drag the boat across a rough surface.
	For each particular water area the local shipping regulations are in force. You may apply for information to the appropriate water transport and shipping directorate, as well as to the water police.
 <p>WARNING</p>	Use the boat equipment and accessories only on their direct purpose to ensure reliable service.
	Even when sailing with an outboard engine you should always have the oars available with you so that you were able to reach the shore without outside assistance in case of any damage of the boat.
 <p>WARNING</p>	On your request any outboard engine seller may provide your engine with the emergency stop switch. During navigation the switch should be connected to the wrist of your hand by means of a cord. In case you fall overboard, even if being a steersman, the switch will cut out the engine and the propeller. This arrangement will enable you to avoid any traumas and to reach the boat.
	Take all possible precautions against penetration of fuel, oil or electrolyte from the storage battery into the inflatable boat. If it does happen wash thoroughly the fouled spots with water.



You should be always sure that the number of people on board never exceeds that specified in the owner's manual or on the builder's plate provided on the transom.

The boat will retain an adequate floatability and will not keel over only provided that the load is arranged reasonably. **Therefore, do not accommodate all passengers on the same side of the boat.**



All passengers should be accommodated inside the boat. The occupied seats should not be left throughout the entire sailing time.



All passengers should put on life-saving jackets.

CHILDREN and non-swimmers MUST WEAR A FLOATATION DEVICE AT ALL TIMES.

Always check that floatation devices for children are of the right size and that they are operational.



Arrange the cargo to be carried uniformly inside the boat, all items being reliable secured on the bottom of the boat.

When sailing with an outboard engine the steersman should shift his body forward in the course of acceleration to prevent the boat forebody from raising under the force of upthrust waves.



Despite the strong shell of the boat we recommend carefully handle and operate with sharp and pricking objects which you have on board . It concerns, for example, a knife blade, fish-hook point, etc.



Approaching to rocky shores, shoals, moles, etc. , please be careful to avoid damages of your boat. It is strictly prohibited to drag the boat across rough surfaces (shingle, rocks, concrete, etc.).

In case of prolonged navigation with the use of an outboard motor, regularly check, that the motor is reliably attached to the boat. If the engine was attached carelessly, the attachment may loosen under the action of vibration.



Besides, at regular intervals, please check air chambers pressure , since the pressure may vary under the effects of outside air temperature and atmospheric pressure variations.

Never forget to monitor regularly the quantity of fuel in the fuel tank. Keep always in mind that the quantity of fuel should be sufficient for you to sail to your final destination.

● Towing



At towing the towing rope length should not be less at least 3 lengths of the boat.

The steersman of the towed boat should be assisted by another crew member to monitor the process of towing. In this case, certain communication gestures should be agreed upon beforehand.



The rope have to be attached to both boats in a manner ensuring its immediately, single-motion release.

● Damage to one of air chambers

The inflatable boat is designed to provide an adequate stability in case of the complete damage to one of the air chambers (balloon compartments) at the expense of the remaining air chambers and the hull. Thanks to it, you will be able to reach safely the nearest shore. Reduce the speed and shift your body to the undamaged part of the boat. Observe changes in stability. After that, immediately head for the nearest shore. To prevent penetration of water into the boat, pull the shell of the damaged air chambers upwards.

● Mooring fast fastening



Attach towing rope in the bow of the boat to the one of the frontal towing rings. Attach bow mooring ropes to the bow mooring cleats only. Attach rear mooring ropes or the rope of back anchor to the rear mooring cleats only.

● Danger of currents and wind



Before begin navigation on the boat, make detail inquiries about local conditions and regulations! Currents, wind, shoals, rising and falling tides, as well as weather variations may imply serious danger!

● In emergency stay in boat

In any unexpected situation (engine failure, boat damage, etc.), never leave the boat, if it is still afloat. Even if you believe that the shore is just nearby, stay in the boat, since you will be looked for in this particular place and, most probably, will be found. Should the boat become partially flooded, throw heavy objects (batteries, fuel tank, engine) overboard to ensure additional floatability.

● Handling under power



Manoeuvrability above 30knots (55 km/h) is limited. Sudden turn may cause loss of control. Reduce speed before sharp turn, in either direction.



**When the boat is fitted with an engine with maximum recommended power it must be use with extreme care.
This application is directed at experienced users using their boats for very specific purposes.**



WARNING

Do not operate your boat with an engine of rated power larger than that stated on the builder's plate in the boat.



ATTENTION

Do not operate this craft at negative propulsion unit trim settings (bow down) at high speed. Craft may lean over on side. Instability in turns may result. Use negative trim to accelerate to planing speed from displacement speed and at lower planing speeds in choppy water (applicable to craft equipped with propulsion unit power trim).



ATTENTION

Do not operate at maximum speed while in congested high traffic waterways or in weather and sea conditions of reduced visibility high winds or large waves. Reduce speed and wake as a courtesy and as a safety consideration to yourself and others. Observe and obey speed limit and no wake zones.



ATTENTION

Observe right-of-way as defined by Rules of the Road and required by COLREG.

Always be certain to have sufficient distance to stop or manoeuvre if required to avoid collisions.

● **WARNING SIGNS AND LABELS.**

In accordance with ABYC standards, warning signs and labels are installed on your boat (if applicable).

Do not remove warning signs and labels. Always check their suitability.

If the warning signs are damaged and you cannot read the text or symbols, you must order new ones from your dealer.

Check with your dealer for the correct warning signs and labels mounting location.

BOAT CAPACITY LABEL.

Place of installation: on the hull of the boat near the stern seat

N610

N570

N520

+

MAXIMUM CAPACITIES

10 PERSONS OR 1650 LBS
 2343 LBS PERSONS, MOTORS, GEAR
 150 H.P. MOTOR

THIS BOAT COMPLIES WITH U.S. COAST GUARD SAFETY STANDARDS IN EFFECT ON THE DATE OF CERTIFICATION

MODEL N610



0.15 bar
2.20 psi

BRIG
USA LLC Annapolis, MD

+

+

U.S. COAST GUARD
MAXIMUM CAPACITIES

10 PERSONS OR 1650 LBS
 2315 LBS PERSONS, MOTORS, GEAR
 120 H.P. MOTOR

THIS BOAT COMPLIES WITH U.S. COAST GUARD SAFETY STANDARDS IN EFFECT ON THE DATE OF CERTIFICATION

MODEL N570



0.15 bar
2.20 psi

BRIG
USA LLC Annapolis, MD

+

+

U.S. COAST GUARD
MAXIMUM CAPACITIES

9 PERSONS OR 1485 LBS
 2122 LBS PERSONS, MOTORS, GEAR
 100 H.P. MOTOR

THIS BOAT COMPLIES WITH U.S. COAST GUARD SAFETY STANDARDS IN EFFECT ON THE DATE OF CERTIFICATION

MODEL N520



0.15 bar
2.20 psi

BRIG
USA LLC Annapolis, MD

+

WARNING. MAXIMUM ENGINE WEIGHT.

Place of installation: on the hull of the boat near the outboard engine.

N610

▲ WARNING
MODEL N610
THIS BOAT HAS BEEN DESIGNED FOR A MAXIMUM OUTBOARD ENGINE WEIGHT OF 645 LBS. READ THE OWNER'S MANUAL

N570

▲ WARNING
THIS BOAT HAS BEEN DESIGNED FOR A MAXIMUM OUTBOARD ENGINE WEIGHT OF 640 LBS. READ THE OWNER'S MANUAL

2077.640

N520

▲ WARNING
MODEL N520
THIS BOAT HAS BEEN DESIGNED FOR A MAXIMUM OUTBOARD ENGINE WEIGHT OF 502 LBS. READ THE OWNER'S MANUAL

WARNING. LEAKING FUEL

Place of installation: on the hull near of the fuel filler.

All models.

▲ WARNING
AVOID SERIOUS INJURY OR DEATH FROM FIRE OR EXPLOSION RESULTING FROM LEAKING FUEL.
INSPECT SYSTEM FOR LEAKS AT LEAST ONCE A YEAR.

WARNING. ROTATING PROPELLER

Place of installation: on the hull near the ladder.

All models.

	▲ WARNING ROTATING PROPELLER OF THE ENGINE
--	--

WARNING. FAILURE TO FOLLOW THESE WARNINGS COULD SEVERE INJURY OR DEATH

Place of installation: on the steering console.

All models.

⚠ WARNING

Failure to follow these warnings could cause SEVERE INJURY or DEATH

- **CARBON MONOXIDE (CO) CAN CAUSE BRAIN DAMAGE OR DEATH.**
 - Engine and generator exhaust odorless and colorless carbon monoxide gas.
 - Signs of carbon monoxide poisoning include nausea, headache, dizziness, drowsiness, and lack of consciousness
 - **MOVE TO FRESH AIR** if anyone shows signs of carbon monoxide poisoning.

- **CHECK WEATHER FORECAST BEFORE DEPARTING DOCK** and heed all weather advisories

- **WEAR SAFETY LANYARD** at all time while operating boat to prevent unmanned operation.

- **NEVER OPERATE WHILE UNDER THE INFLUENCE** of drugs or alcohol.

- **DO NOT OVERLOAD THE BOAT. ENSURE THAT WEIGHT IS PROPERLY AND EVENLY DISTRIBUTED** fore and aft and on both side of the boat to avoid poor handling, sudden loss of control, swamping and/or capsizing.

- **PASSENGERS SHOULD WEAR U.S. COAST GUARD APPROVED LIFE JACKETS.**

- **MAKE SURE THAT ALL PASSENGERS ARE PROPERLY SEATED WHILE UNDERWAY.** To avoid passengers falling overboard or being ejected from the boat, do not allow passengers to sit on seat backs, gunwales or outermost deck edges while boat is moving.



- **REDUCE SPEED BEFORE ATTEMPTING SUDDEN OR SHARP TURNS, AND MAINTAIN SAFE SPEEDS** for water conditions and environment at all times. Maneuverability at high speeds is limited, and sudden turns may cause loss of boat control.

- **KEEP PROPER LOOKOUT AND SAFE DISTANCE** for the conditions at all time to avoid collisions.

- **OBEY APPLICABLE NAVIGATION RULES AND BOATING LAWS.**

- **USE CAUTION AND PROPER LIGHTING** during night time and boating in adverse weather.

- **READ THE OWNER'S MANUAL AND COMPLETE THE BOAT'S PRE-OPERATION CHECKLIST** prior to boat operation.





MODEL

N520

N570

N610

SERIAL No.

UA-QRK

Date of manufacture

Quality inspection stamp

NOTE: The inflatable boat was delivered with the following equipment installed:

1.Fuel tank	Stamp and signature	5.Steering system	Stamp and signature
2.Electric system	Stamp and signature	6.Engine power system	Stamp and signature
3.Drain system	Stamp and signature	7.Engine installation, test and completion of plants and fittings done by	Stamp and signature
4.Bilge pump	Stamp and signature		